

# Operating Manual

## E300 SPOTTER



E300 SPOTTER Operating Manual  
**TABLE OF CONTENTS**

<u>TOPIC</u>	<u>PAGE #</u>
• Introduction	3
• Technical Specifications	4
<b><u>SECTION 1: Operational Safety</u></b>	
• Electrical Safety	5
• Mechanical Safety	6
<b><u>SECTION 2: Operation Procedures</u></b>	
• Electrical Supply	7
• Water Supply & Chemicals	7
• Solution & Vacuum Hoses	7
• Starting System - Switches	8
• Shutdown Procedures	9
• Troubleshooting	10-11
• Solution Flow Path E300	12
• Wiring Diagrams E300	14
<b><u>SECTION 3: Maintenance/ Technical</u></b>	
• Maintenance	18
• Parts	21
○ E300	22
○ Hoses & Tool	36
• Warranty	37



## Introduction

Congratulations on your purchase of the E300 SPOTTER. The E300 is designed to combine versatility with ease of transport. Years of experience, engineering, and planning have gone into the design and manufacturing of the E300 SPOTTER. We take a great deal of pride in the E300 SPOTTER; our goal is no less than your complete satisfaction.

This manual will provide users with the knowledge required to operate the E300 SPOTTER safely, to understand how to properly operate and maintain the machine, and to ensure that the equipment operates at its maximum performance level.

**All users must read and understand this manual completely before operating the machine.**

Always maintain this manual in legible condition adjacent to the E300 SPOTTER, or place in a secure location for future reference.

# Technical Specifications

## E300 SPOTTER

Height:	19"
Length:	21"
Width:	10"
Weight:	18lbs.
Solution Tank Capacity:	3 gallon
Recovery Tank Capacity:	3 gallon
Power Cord:	20 foot – 16/3
Solution Outlet	1/8" Male Quick Connect
Solution Pump:	Flojet ET508224-HP pump 55 psi – 0.37gpm
Vacuum Motor:	AMETEK Lamb 4.8" Diameter – Peripheral discharge Two Stage 87.7cfm – 76.5" WC
Power Draw:	6.42 / 7.3 amps

## Safety

**CAUTION!** This machine is an electrical appliance. Care must be taken to reduce the risk of electrical shock.

- **READ AND UNDERSTAND ALL INSTRUCTIONS BEFORE OPERATING THE E300 SPOTTER.**
- To reduce the risk of property damage or injury, repairs to electrical systems should only be performed by experienced technicians. Contact your distributor for assistance. Unplug machine power cord from outlet before performing any repairs on the extractor.
- This machine shall be grounded while in use to protect the operator from electric shock. The machine is provided with a three-conductor cord and a three-contact grounding type attachment plug to fit the proper grounding type receptacle. The green (or green and yellow) conductor in the cord is the grounding wire. Never connect this wire to other than the grounding pin of the attachment plug.
- This machine is for use on a nominal 120-volt circuit and has a grounding plug that resembles the plug illustrated in the sketch to the right. Make sure that the machine is connected to an outlet having the same configuration as the plug. No plug adapter should be used with this machine.
- The power cord supplied with this machine is properly sized to handle the electrical load of this machine and properly grounded as described above. Any extension cords used with this machine must be similarly sized and grounded to assure safe operation. A properly sized GFCI protected cord can be used for additional protection.
- Do not use the E300 SPOTTER outdoors, in standing water or on wet surfaces. Do not store the E300 in wet conditions. If extractor is leaking, unplug machine power cords from outlets before approaching or touching machine.
- Do not unplug power cord by pulling on the cord. Grasp the plug end when unplugging the cord. Do not pull the extractor by the cord. If cord or plug is damaged, do not use cord. Replace with new cord or repair as needed before use.
- Overloaded circuit may not always trip circuit breaker. Reduced voltage to machine on overloaded circuit will prevent components from operating properly.

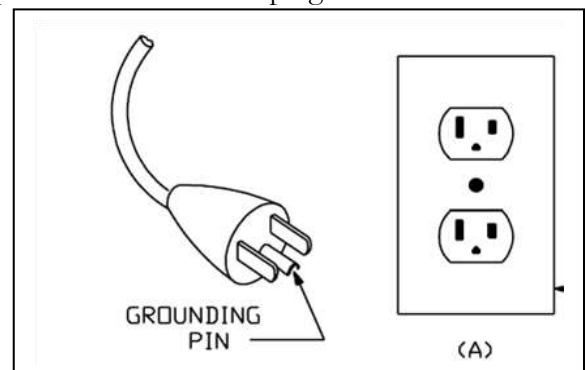

**WARNING!** This machine must be protected from conditions which may damage the pump, tank, hoses and other components.

- **Freezing of water in this machine will cause serious damage.** The E300, solution hoses, and tools must be protected from freezing temperature. Store, transport, and use this equipment only in temperatures well above freezing. (32°F or 0°C). If you suspect the E300 has been frozen, do not plug in or turn on machine until you are sure it has thawed completely.
- If the equipment cannot be stored or transported in a warm environment, it can be guarded from freezing by running an anti-freeze solution through the incoming water lines, chemical feed system, solution pump, solution lines, tools and pump-out pump. The machine is filled at the factory with anti-freeze to eliminate damage during shipment in cold weather.
  - The anti-freeze solution must be completely flushed from the machine before it is returned to service.
- The E300 must not be used to pick up flammable or combustible materials or used in areas where these materials may be present.
- Solvent-based or water-based solutions containing solvents may damage the pump, hoses, and other components. Do not assume chemical compatibility.
- Do not clean with solutions that are at temperatures above 100°F.
- Rinse the solution tank, chemical system, and pump with fresh water after each day's use.
- Do not allow pump to run dry. Always maintain adequate solution level to supply solution pump.
- Solution hoses may rupture if worn or damaged. Do not use solution hoses if hose covering is cut, bulging, or otherwise damaged. Examine solution hoses daily and replace or repair hoses as needed.
- Keep Vacuum Filter Cap clean and check float for proper operation. Do not operate the E300 without the Vacuum Filter Cap in place. **Use defoamer to eliminate foam build-up during cleaning and prevent foam/moisture from entering vacuum.**

**\*\*\*Use common sense to protect yourself and others while using this equipment.\*\*\***

- Keep pets and children away from the machine when in use.
- Keep all body parts, hair, and loose clothing away from openings and moving parts. Always wear appropriate clothing and safety equipment when operating unit.
- Use extra care when cleaning on stairs. Wet carpet on stairs can be slippery.
- Secure latch before moving. Lift using only the appropriate handle.
- Water may be spilled, drip, or be exhausted from vacuums during operation. Place unit in area where water will not cause damage or use drop cloth to protect surfaces.

## Operation Procedures

*Knowledge of the proper operation of the E300 is required to ensure user safety and efficient performance of the extractor.*

- ❖ **Prior to using the E300 for the first time the Anti-Freeze used to protect the unit during shipping must be flushed from pump, hoses & tool. Pour one quart of clean water into the solution tank, connect cord, hoses & tool. Spray the tool into a bucket or sink to flush out the ant-freeze before using the E300 for cleaning.**

## SET UP AND OPERATION

### 1. Electrical Cord:

Plug the power cord into the 120volt wall outlet. Make sure the circuit can handle the power load the operation of the E300 will place on the circuit.

### 2. Water Supply & Chemical Mixing– Manual Fill:

- Pour up to 3 gallons of hot water into the solution tank at the front of the machine. This will fill the tank to a level approximately 4 inches from the top of the tank.  
**The water temperature should not exceed 120°F.**
- Measure and add the appropriate amount of the desired liquid chemical to the water in the solution tank. The amount of chemical will vary depending on the type of chemical used, the amount of water in the tank, and the material being cleaned; consult the chemical packaging for specific mixture ratios.
- Powdered chemicals should be dissolved in water in a separate container before being added to the water in the solution tank.

### 3. Connection of Hose:

Connect the solution hose to the solution outlet male quick connect on the front of the machine. The other end of the hose should always be connected to the cleaning tool.

The Vacuum Hose is connected to the barb on the recovery tank of the E300. The 1-1/2” cuff on the vacuum hose is simply pushed onto the barb. The 1-1/2” cuff on other end is connected to the cleaning tool. **Add defoamer to the recovery tank to prevent foam build-up in recovery tank during cleaning and to keep foam/moisture from entering vacuum.**

#### **4. Starting the Spotter - Power Switches:**

The new style E300 without heat has two switches, one to turn on the vacuum motor & one to turn on the solution pump.

When you are ready to start cleaning, turn the switches to the ON position. For standard cleaning turn on both switches. For extraction only, you can turn on just the Vacuum Switch. The FloJet solution pump, standard on the E300 is self-priming and usually additional priming procedures are not required.

If the pump does not prime by itself, or if flow is low or unsteady, check the hose from the solution tank to the pump and the filter screen for clogging, kinks, or restrictions. Clean or replace hose and/or filter and. Turn switch ON. Check the valve operation and the jet on the tool for flow restriction that can affect solution flow.

If you are having trouble with the pump, refer to the trouble shooting guide or contact your distributor for advice or assistance.

#### **5. Spotter Operation:**

As you operate the spotter the water and soil you vacuum up will collect in the recovery tank. The E300 is equipped with a Float Shutoff assembly which will block the vacuum air flow when the tank is filled. The float rises with the water level in the recovery tank until it gets to the top, blocking the vacuum air flow. When this happens you will notice a change in the sound of the vacuum motor. This is your signal to turn off the unit and empty the recovery tank. Disconnect the hoses and drain the tank by pouring the water out of the vacuum barb. Do not attempt to drain the recovery tank from the hatch cover opening. Do not use the same bucket to drain the unit that you use to fill the solution tank. Add more defoamer to the recovery tank before you resume cleaning.

After draining the tank, before you place the recovery tank back onto the spotter base, check the water level in the solution tank and add more water and detergent as needed to complete your cleaning. Then place the recovery tank back onto the solution tank, reconnect the hoses and resume cleaning.



## Shutdown Procedures:

- ❖ When finished cleaning, turn off all switches.
- ❖ Disconnect the power cord from the outlet.
- ❖ Disconnect the solution hose and vacuum hose from the E300. Pull valve trigger to release pressure from the hose before disconnecting solution hose.
- ❖ Drain any remaining water from the solution tank and the recovery tank and dispose in sanitary drain. Drain the recovery tank by pouring the water out of the vacuum barb. Do not attempt to pour the water out the recovery tank hatch cover opening. Do not use the same bucket to drain the tank that you use to fill the tank.
- ❖ Remove the float shutoff assembly from the recovery tank and clean filter & float as needed.
- ❖ Replace shutoff assembly and tank lid.
- ❖ Roll up power cord. Collect and store E300, hoses, tool, and any other accessories.

# Troubleshooting

## Troubleshooting – E300

Problem	Cause	Solution
Machine not turning on - No power	Building circuit breaker tripped.	Reset breaker or move cord to other outlet
	Faulty power cord	Replace cord
	Faulty switches or internal wiring	Check wiring & test switches - Repair as needed *
Solution Pump not running	Building circuit breaker tripped.	Reset breaker or move cord to other outlet.
	Faulty power cord	Replace cord
	Faulty switches or internal wiring	Check wiring & test switches - Repair as needed *
	Pump faulty	Replace Pump (AP30)
Low Solution Pressure and/or Pulsation	Jet too large for pressure desired	Check jet size & flow rates use smaller jets
	Jet worn allowing too much flow	Replace jet
	Solution inlet filter plugged	Clean or replace filter
	Hose from solution tank restricted	Repair or replace hose
	Heater Restricted with scale (MA51H Only)	De-scale or replace the heater
	Pressure Relief valve stuck open (MA51H Only)	Replace the pressure relief valve
	Pump intake hose or fittings leaking	Repair or replace hose. Tighten clamps or replace fittings
	Solution tank empty	Add water to tank - Check & repair auto fill assembly
	Pump faulty	Repair or replace pump
	Tool valve faulty	Repair or replace valve
Can't connect solution hose to machine	Pressure in lines	Turn off pump - Release pressure
	Quick connects faulty	Replace quick connects
	Wrong style/size quick connects	Replace quick connects to match connects on machine
<p>* To reduce the risk of fire electrical shock or injury repairs to wiring should only be performed by experienced service technicians. If you are not experienced in checking electrical wiring contact your nearest authorized service center to perform tests and repairs to wiring and switches.</p>		

<b>Problem</b>	<b>Cause</b>	<b>Solution</b>
Vacuum Motor not running	Building circuit breaker tripped.	Reset breaker or move cord to other outlet
	Faulty power cord	Replace cord
	Faulty switch or internal wiring	Check wiring & test switch - Repair as needed *
	Vacuum motor faulty	Replace vacuum motor
Loss of Vacuum	Vacuum motor faulty	Replace vacuum motor
	Vacuum motor gasket damaged	Replace gasket
	Recovery tank lid gasket damaged	Replace lid assembly or gasket
	Vacuum hose or tool clogged	Clean out vacuum hoses and tool
	Vacuum hoses or cuffs leaking	Replace vacuum hoses, cuffs & connectors as needed
	Recovery tank full	Drain tank
	Float shutoff filter clogged	Clean float shutoff filter
	Float shutoff stuck	Repair or replace float shutoff
	Recovery tank damaged	Replace recovery tank
Tool won't spray - low or uneven spray	Jet clogged	Clean out or replace jet
	Inline filter clogged	Clean out or replace filter if so equipped
	Jet worn	Replace jet
	Jet not aligned properly	Re-align jet
	Tool valve faulty	Repair or replace valve
	Quick connects or hoses restricted	Clean out or replace quick connects and/or hoses
	Pump not pumping	See Troubleshooting sections relating to solution pump
<p>* To reduce the risk of fire electrical shock or injury repairs to wiring should only be performed by experienced service technicians. If you are not experienced in checking electrical wiring contact your nearest authorized service center to perform tests and repairs to wiring and switches.</p>		

Contact your distributor for additional troubleshooting assistance, to order parts, or for advice and assistance in performing necessary repairs.

# E300

## Solution Flow Path

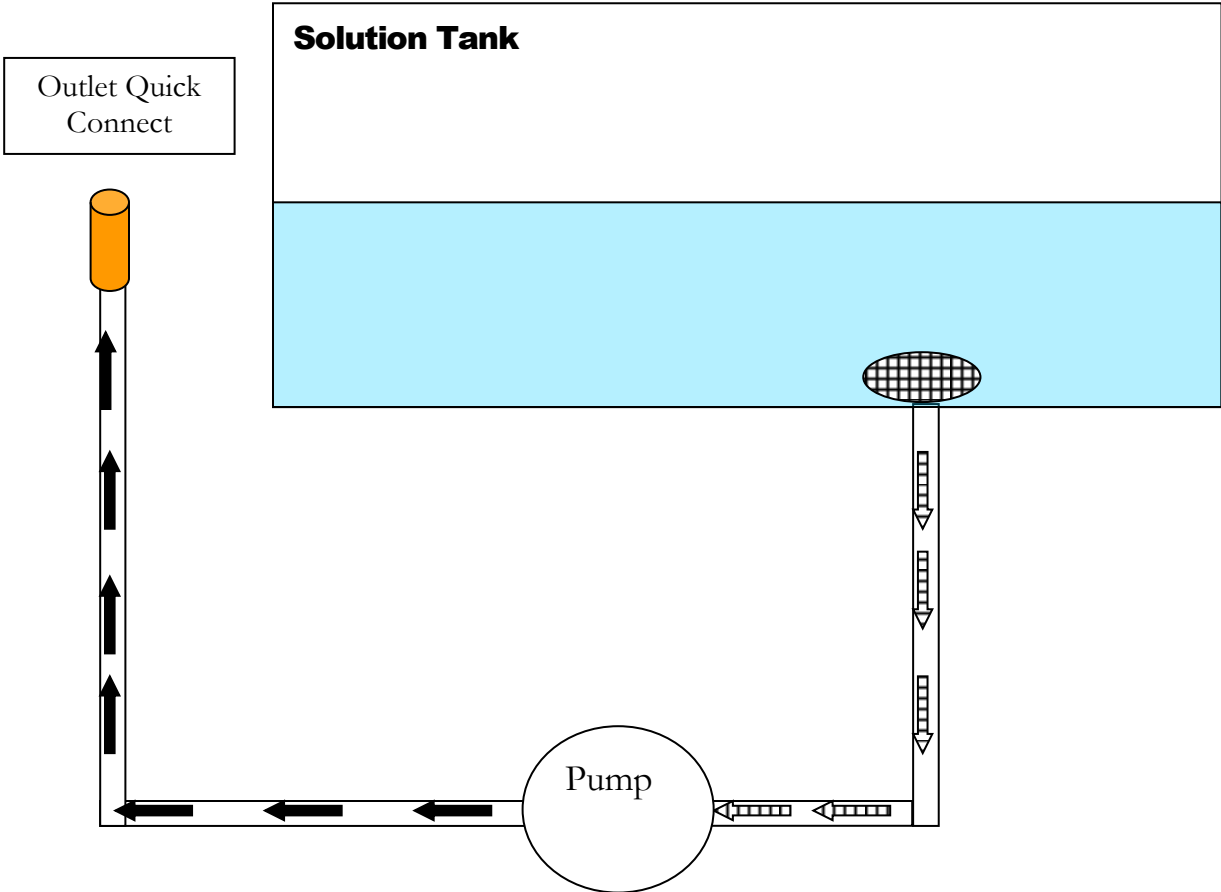

Denotes incoming water flow



Denotes Water flow in pressure hose



# E300 Wiring Diagram - Standard

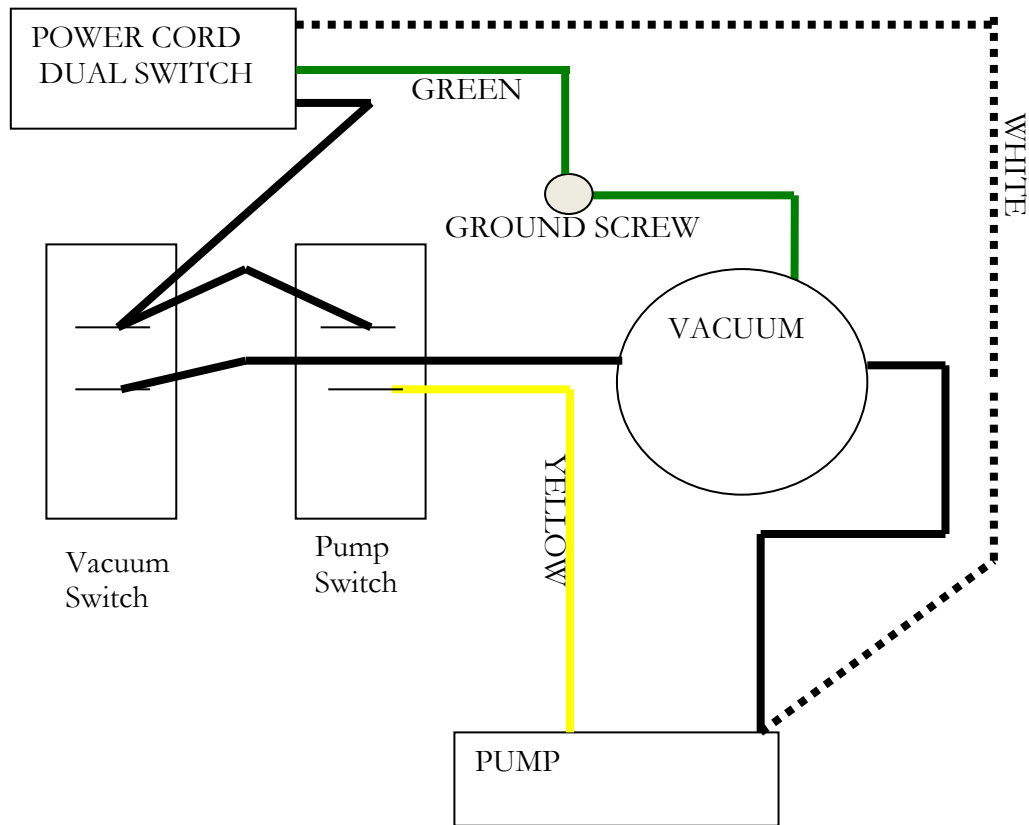

## E300 SWITCH PANEL



## Maintenance

*Proper maintenance is required to keep the E300 operating properly, prevent downtime and to extend the life of your equipment.*

**WARNING:** Disconnect electrical power before performing any service or maintenance inside machine base or before testing or repairing switches or power cords. Failure to do so may result in severe personal injury or death.

OPERATION	INTERVAL	Page #
CLEAN VACUUM SHUTOFF ASSEMBLY	Daily – After Each Job	19
RINSE OUT RECOVERY TANK	Daily	19
FLUSH SOLUTION TANK AND PUMP	Daily	19
CLEAN PUMP-INLET FILTER	Daily	19
DESCALING HEATER – MA51H ONLY	As needed	20
REMOVING BASE	As needed	20
STORAGE PREP – FREEZE PROTECTION	As needed	20

## **CLEAN VACUUM SHUTOFF ASSEMBLY:**

Inside the recovery tank, on top of the stand pipe, is the Vacuum Shutoff Assembly. It functions to prevent debris and water from being sucked into the vacuum motors. Operating the E300 without the Vacuum Shutoff Assembly or with a poorly maintained assembly will greatly decrease the life of the vacuum motors and will void the warranty.

If debris builds up on this filter, it will reduce the vacuum air flow and may cause a significant decrease in the rate of water recovery. If debris prevents the float from moving or seating inside the assembly, it may not stop the airflow when the tank fill with water, and the water will be sucked into the vacuum and blown out the exhaust. **Always use defoamer to prevent foam or moisture from entering vacuums.**

To clean:

1. Twist to loosen and pull the assembly off of the stand pipe.
2. Pull fibers and lint off and rinse with clean water.
3. Push the assembly back onto the stand pipe and replace the recovery tank lid.

## **RINSE OUT RECOVERY TANK:**

Clean out the tank on a regular basis to extend the life of vacuum & recovery components as well as keep the tank smelling better.

1. Remove the recovery tank lid.
2. Use a hose to rinse the dirt and debris out of the recovery tank.
3. Spray the tank with a deodorizer or disinfectant.
4. Replace the recovery tank lid.
5. Dispose of the dirty water and debris.

## **FLUSH SOLUTION TANK AND PUMP:**

1. Pour one gallon of clean water into the solution tank. Slosh the water around in the tank to clean tank and pour water out and dispose of the dirty water.
2. Pour another gallon of clean water into the tank.
3. With Cord plugged in, connect the solution hose& tool to the solution outlet male quick connect.
4. Direct the tool into a bucket or sink and turn the solution pump ON.
5. Spray the tool into the bucket or sink until most of the water has been pumped out of the solution tank
6. Turn the pump OFF and disconnect the solution hose and tool.
7. Drain the remaining water out of the solution tank and dispose of the dirty water.

If there is a heavy chemical build-up in the machine, hoses, or tools, a mild acid can be added to the rinse water in the previous procedure.

## **CLEAN PUMP INLET FILTER**

A restricted Pump Inlet Filter can prevent the solution pump from providing adequate pressure for cleaning.

- Remove the stainless steel filter screen and clean as needed.
- Do not operate the machine without the pump inlet filter in place.
- Replace filter, hose & barb as needed.

## **Storage Prep and Freeze Protection Procedures:**

Your E300 must be protected from freezing. Freezing can cause serious damage to the pump, pump-out, auto-fill float valve, and any other component containing water. If the E300 is transported or stored in freezing temperatures, the following procedures should be performed.

1. In a separate container mix 1 pint of water with 1 pint of automotive radiator anti-freeze. (Ethylene glycol type). Mix well and pour into the solution tank.
2. Connect the solution hose to the solution outlet male quick connect and hold the tool over a bucket.
3. Turn the solution pump switch to the ON position. Spray the tool into the bucket until you see the anti-freeze solution coming out of the jet into the bucket.
4. Turn the solution pump off.
5. Drain the remaining anti-freeze solution from the solution tank and the machine is ready for storage.

## **RETURNING THE E300 TO SERVICE AFTER STORAGE OR FREEZE PROTECTION:**

To return the E300 to service, the anti-freeze must be flushed from the machine. Flush the anti-freeze out of the machine by repeating the procedure above using one quart of clean water in place of the anti-freeze solution.



## Parts

*Replacement parts available for repair of your E300.*

### **E300 Spotter Pump – 515-500**



### **E300 Vacuum Motor – 355-125**



1/4" NYLON BARB X 1/8" MPT

1/8" HEX NIPPLE

PUMP  
515-500

1/4" ID NYLON BRAIDED  
HOSE

1/4" NYLON BARB/ ELBOW - 1/8" MPT

VACUUM MOTOR  
355-125

WHEELS (QTY 2)

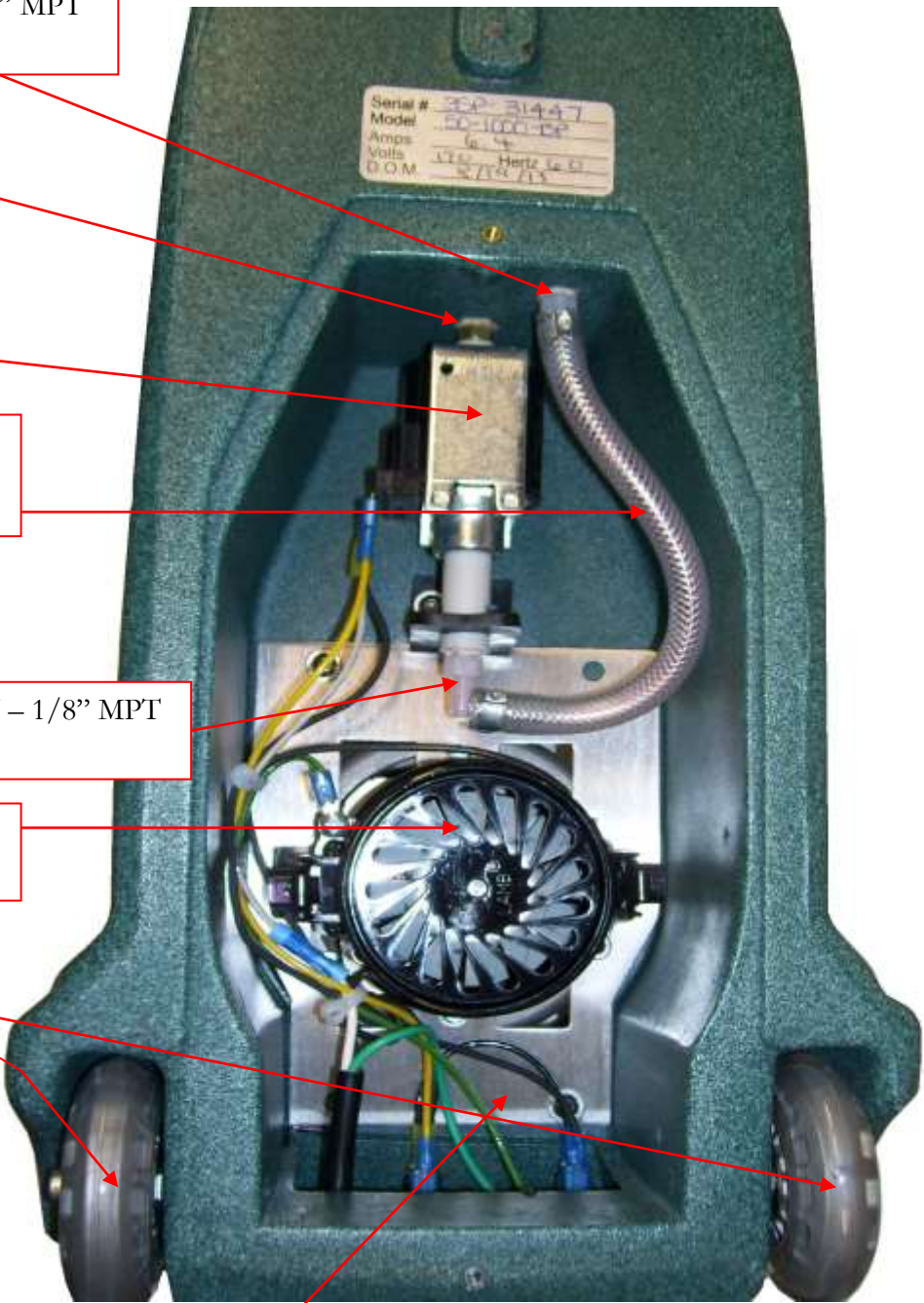

VACUUM GASKET

VACUUM SCREEN



# E300

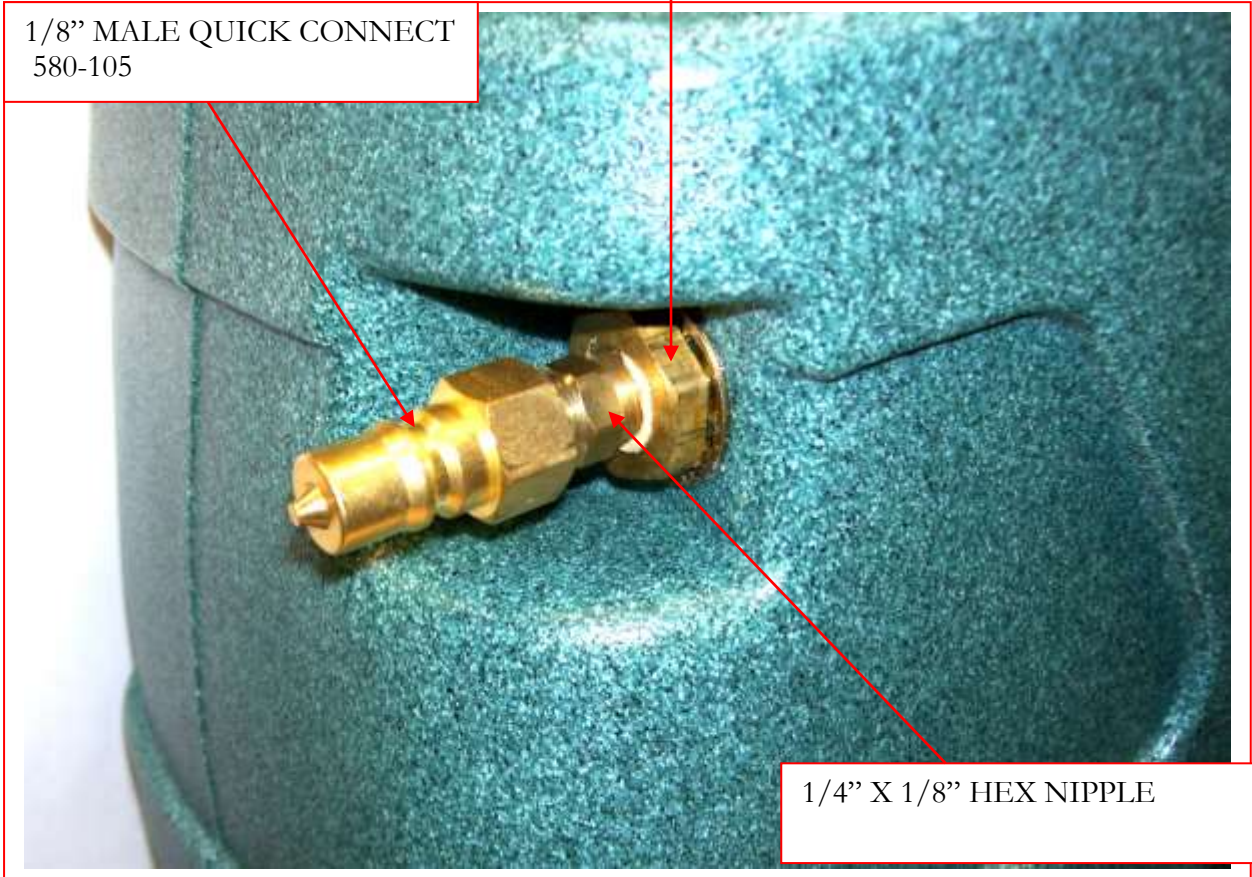
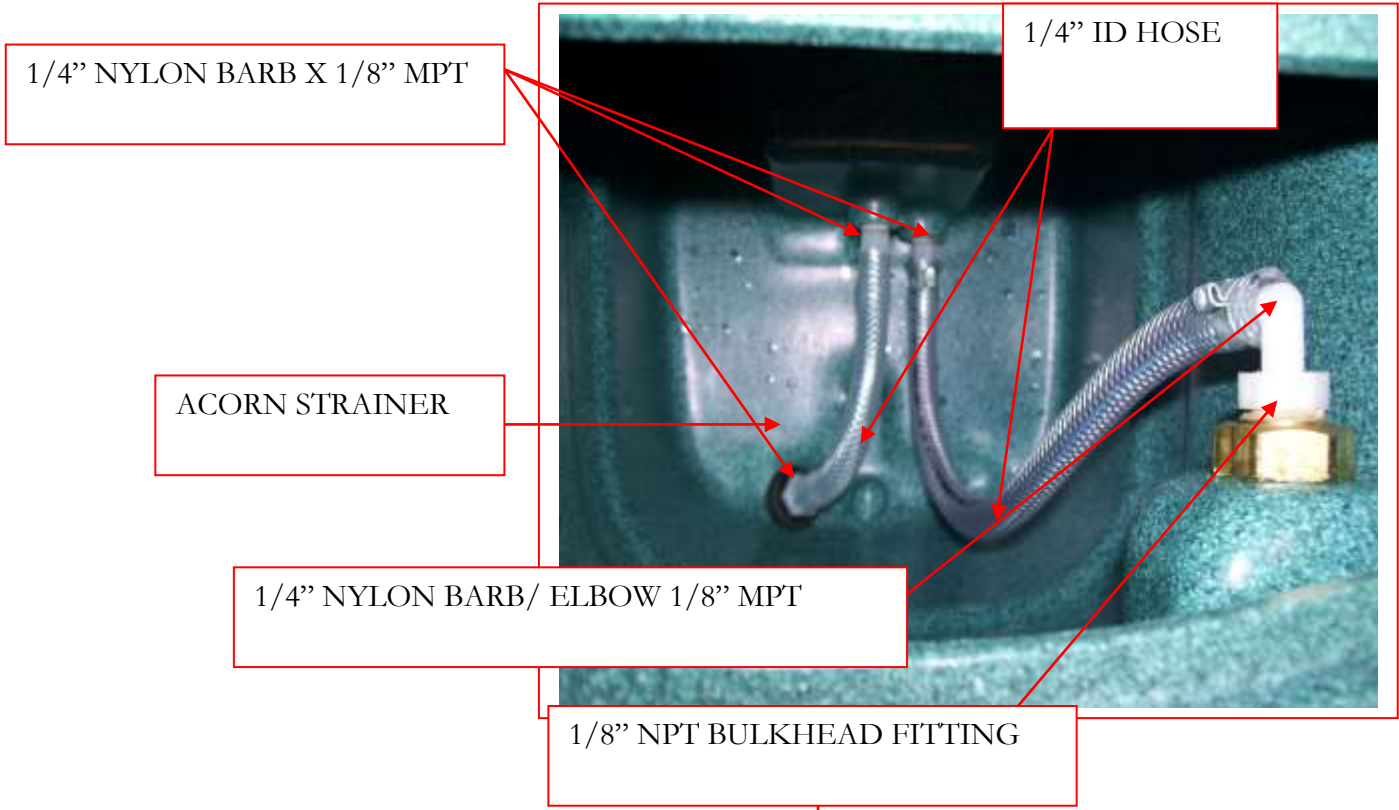

# E300

VACUUM FILTER





SPOTTER CAP & FILTER  
BOTTOM VIEW  
(Part of 10-0304 Assembly)



SPOTTER HATCH, CAP,  
FILTER & FLOAT ASSEMBLY  
10-0304  
GASKET – 10-0302-A

SPOTTER HANDLE - BLACK



RECOVERY TANK

SOLUTION TANK

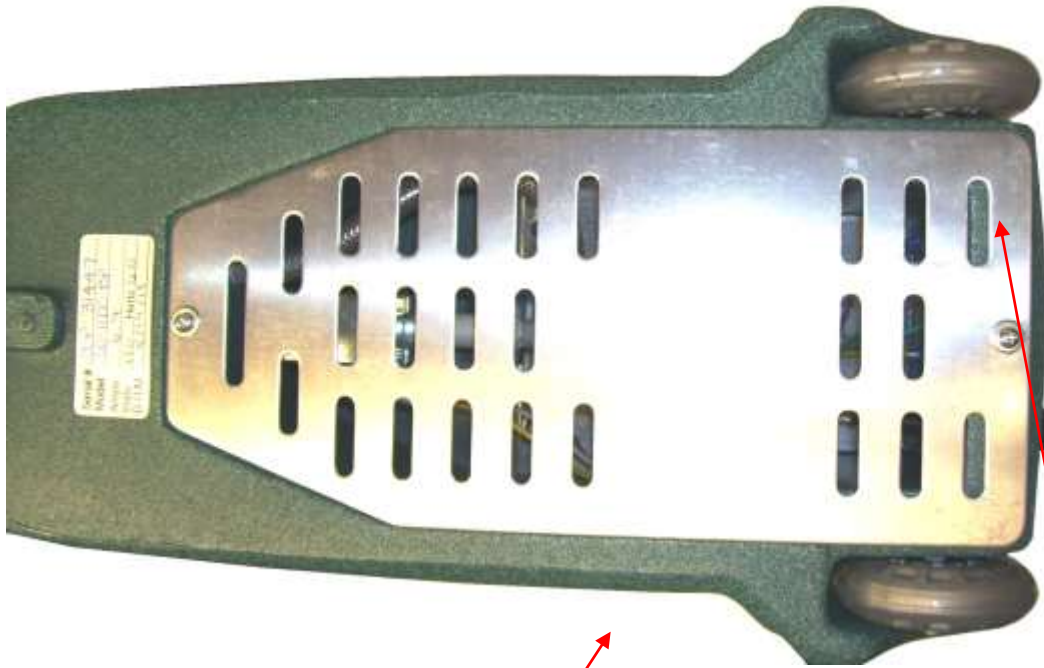

BOTTOM BASE PLATE

WHEELS (QTY 2)

LATCH

LATCH KEEPER

SOLUTION TANK

SWITCH  
305-073

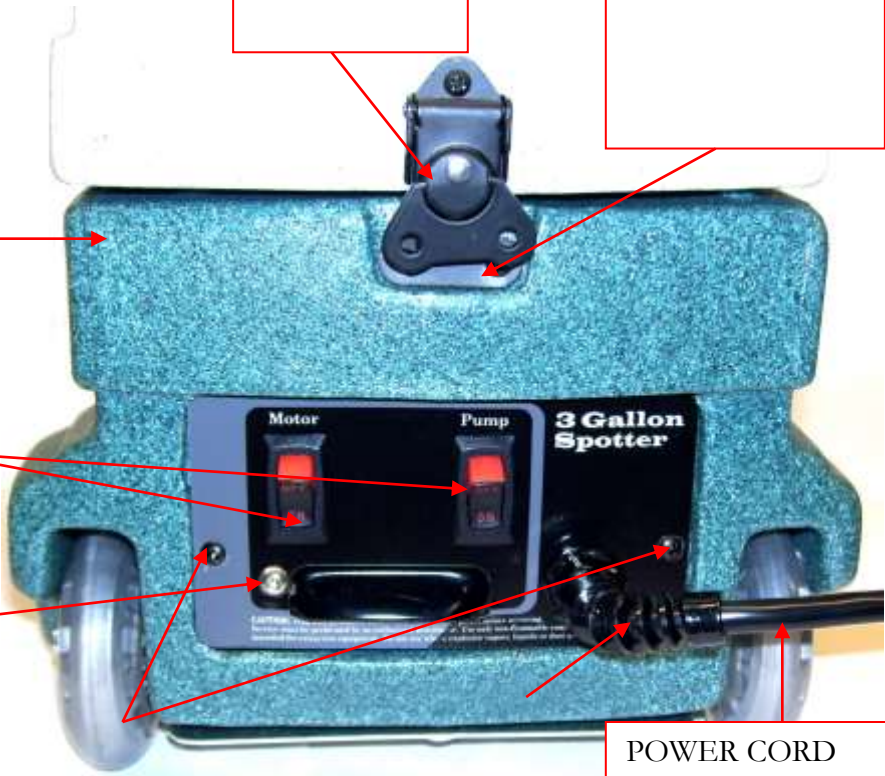

POWER CORD

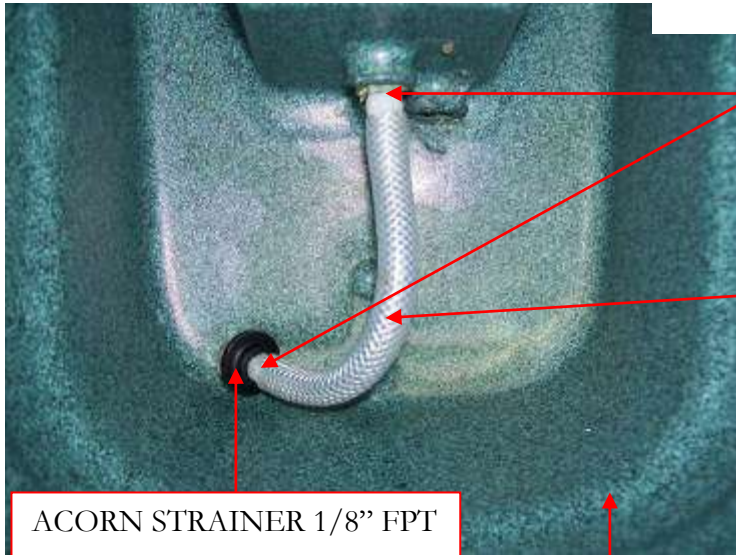

BARB 1/4" X 1/8" MPT

1/4" ID HOSE

ACORN STRAINER 1/8" FPT

SOLUTION TANK



BULKHEAD FITTING 1/4" NM5087

NIPPLE 1/4" HEX BR072

1/4" MALE QUICK CONNECT AH102B



# HAND TOOL AND HOSE ASSEMBLY (255-201)

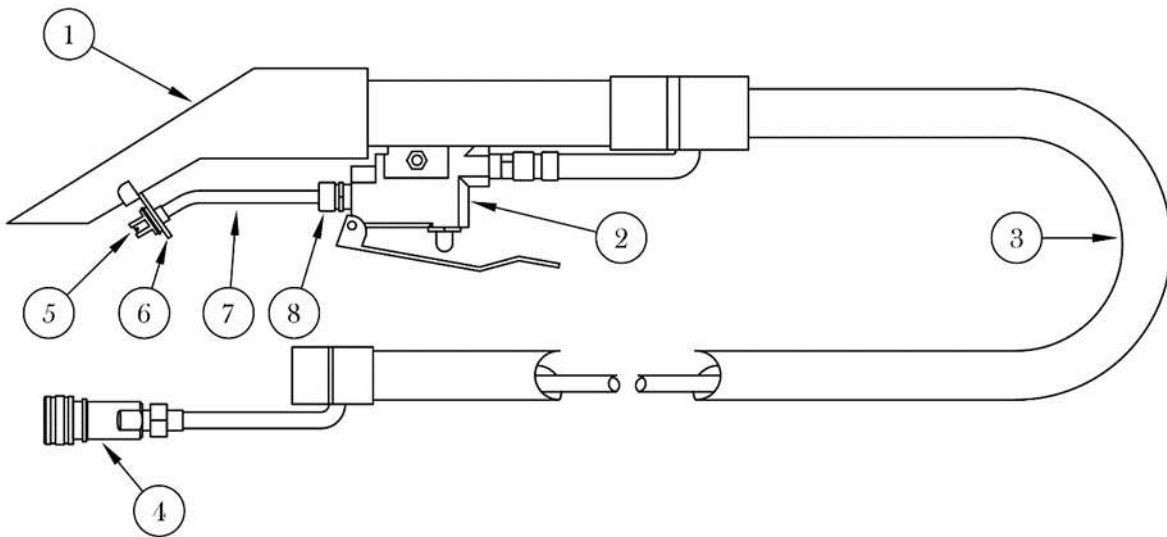

REF	QTY	DESCRIPTION	PART NO.	NOTES:
1	1	HOUSING & TUBE ASSEMBLY	<b>553-206</b>	
2	1	VALVE	<b>535-105</b>	
	1	VALVE HANGER	<b>538-212</b>	NOT SHOWN
3	1	HOSE ASM, VAC/SOLUTION	<b>263-400</b>	
4	1	Q.C. 1/8" FEM (CLOSED)	<b>580-100</b>	
5	1	JET, ASM W/O RING	<b>562-100</b>	
6	1	PLATE, RETAINER W/HARDWARE		PART OF 564-255
7	1	MANIFOLD, SPOTTER	<b>564-255</b>	
8	1	FTTG, 1/8MPT X 3/16 COMP		PART OF 564-255
	1	HAND TOOL, SPOTTER	<b>255-201</b>	ENTIRE ASSEMBLY AS KIT

## Limited Warranty

Your E300 is designed to give you years of reliable service. If a problem should arise use the troubleshooting section in the operation manual to diagnose and correct the problem if possible.

If you are unable to determine the cause or solution to the problem contact your distributor or Esteam for assistance.

ESTEAM MFG LTD warrants the roto-molded tanks and base of the E300 to be free from defects in material or workmanship for five years from the date of purchase.

All other components of the E300 are warranted to be free of defects in material and workmanship for one year from the date of purchase.

During the warranty period, ESTEAM MFG LTD will, at its option repair or replace components which prove to be defective. This warranty does not provide for replacement of complete units due to defective components. Any costs for transportation or related service labor are not covered in this warranty. Replacement parts are warranted only for the remainder of the original warranty period.

This warranty shall not apply to defects resulting from improper operation, lack of maintenance, unauthorized modification, chemical incompatibility, misuse, abuse or exposure to freezing temperature conditions. It does not cover normal wear items such as o-rings, valve seals, pump seals, hoses, jets, cords, batteries, or other items which require replacement as a result of ordinary usage.

To obtain warranty service for the E300, contact your distributor. If the spotter must be returned to an authorized ESTEAM MFG LTD service center, the purchaser shall prepay shipping charges for products returned for warranty service. No returned items will be accepted by ESTEAM MFG LTD without prior authorization. All returns must have a return authorization number, issued by ESTEAM MFG LTD, clearly marked on the exterior of the package.

Esteam makes no other warranty either expressed or implied with respect to this product.

The remedies provided herein are the purchaser's sole and exclusive remedies. In no event shall Esteam be liable for any direct, indirect, special, incidental or consequential damages.

This warranty gives you specific legal rights. You may also have other rights which vary from jurisdiction to jurisdiction.