

ESTEAM CLEANING SYSTEMS

DEFENDER 500 MODELS

OWNER'S MANUAL

Congratulations on your selection of a new Defender portable carpet cleaner built in Canada by Esteam Cleaning Systems. Our goal is to produce the best, high performance line of carpet cleaning equipment on the market today. Reading your Owner's Manual will help to achieve maximum benefit from your purchase.



TABLE OF CONTENTS

<u>TOPIC</u>	<u>PAGE #</u>
• Introduction	3
• Technical Specifications	4
• Safety	5
• Operations	7
• Maintenance	9
• Optional Equipment	10
• Trouble Shooting	11
 <u>Technical</u>	
• Warranty	14
• Defender 500 Drawings & Parts Lists	18
• Defender 500 With Heat Drawings & Parts Lists	30
• Internal Heatermate	42
• Defender 500 2 – 3 Stage Drawings & Parts List	44
• 500PSI Pump Drawings & Parts List	56

Introduction

Congratulations on your purchase of the Defender 500. The Defender 500 is designed to give truckmount-level performance in a portable machine that combines versatility with ease of transport. Years of experience, engineering, and planning have gone into the design and manufacturing of the Defender 500. We take great pride in our equipment; our goal is no less than your complete satisfaction.

The Defender 500 is intended for commercial use only.

This manual will provide users with the knowledge required to operate the Defender 500 safely, to understand how to properly operate and maintain the machine, and to ensure that the equipment operates at its maximum performance level.



All users must read and understand this manual completely before operating the machine.

Always maintain this manual in legible condition adjacent to the Defender 500, or place it in a secure location for future reference.

Any questions pertaining to the operating or servicing of this unit should be directed to your nearest Esteam distributor.

This manual is written specifically for the Defender 500 portable extractor units manufactured by Esteam Manufacturing.

Information in this manual is subject to change without notice and does not represent a commitment on the part of Esteam Mfg., or its parent or affiliated companies.

Technical Specifications

	<i>Defender 500 Defender 200-20</i>	<i>Defender 500-05 Defender 200-20-05</i>	<i>Defender 500-10 Defender 500-20-10</i>
<i>ELECTRICAL</i> Amps Volts	One cord 115 amps 115 volts or 220 volts	Two cords 15 amps per cord 115 volts or 220 volts	Two cords 15 amps per cord 115 volts or 220 volts
<i>VACUUM MOTOR</i> Cfm's Vacuum lift	Single 3 Stage (LRG- Plastic) 94 135"	2-3 stage High Performance 101 185"	Single 3 Stage (LRG- Plastic) 94 135"
<i>PUMP</i>	500 PSI Plunger ¼ HP A/C	500 PSI Plunger ¼ HP A/C	500 PSI Plunger ¼ HP A/C
<i>INTERNAL HEATER</i>	N/A	N/A	1850 watt / 200°F
<i>SOLUTION TANK</i> (Clean water)	12 gallons (45 litres)	12 gallons (45 litres)	12 gallons (45 litres)
<i>RECOVERY TANK</i>	12 gallons (45 litres)	12 gallons (45 litres)	12 gallons (45 litres)
<i>LENGTH</i>	34 inches (86 cm)	34 inches (86 cm)	34 inches (86 cm)
<i>WIDTH</i>	23 inches (58 cm)	23 inches (58 cm)	23 inches (58 cm)
<i>HEIGHT</i>	42 inches (106 cm)	42 inches (106 cm)	42 inches (106 cm)
<i>WEIGHT</i>	117 lbs (53.07 kgs)	122 lbs (55.34 kgs)	127 lbs (57.61 kgs)

Safety

⚠ WARNING

This machine is an electrical appliance.

Care must be taken to reduce the risk of electrical shock.

READ AND UNDERSTAND ALL INSTRUCTIONS BEFORE OPERATING THE DEFENDER 500.

- To reduce the risk of property damage or injury, repairs to electrical systems should only be performed by experienced technicians. Contact your distributor for assistance. Unplug machine power cord from outlet before performing any repairs on the extractor.
- This machine shall be grounded while in use to protect the operator from electric shock. The machine is provided with a three-conductor cord and a three-contact grounding type attachment plug to fit the proper grounding type receptacle. The green (or green and yellow) conductor in the cord is the grounding wire. Never connect this wire to other than the grounding pin of the attachment plug.
- This machine is for use on a nominal 120-volt circuit and has a grounding plug that resembles the plug illustrated in the sketch to the right. Make sure that the machine is connected to an outlet having the same configuration as the plug. No plug adapter should be used with this machine.
- The power cords supplied with this machine are properly sized to handle the electrical load of this machine and properly grounded as described above. Any extension cords used with this machine must be similarly sized with an equal or greater load rating and grounded to assure safe operation. A properly sized or rated GFCI protected cord can be used for additional protection.
- The two power cords must be plugged into separate circuits during operation.
- Do not use the DEFENDER 500 outdoors, in standing water or on wet surfaces. Do not store the DEFENDER 500 in wet conditions. If extractor is leaking, unplug machine power cords from outlets before approaching or touching machine.
- Do not unplug power cord by pulling on the cord. Grasp the plug end when unplugging the cord. Do not pull the extractor by the cord. If cord or plug is damaged, do not use cord. Replace with new cord or repair as needed before use.
- Overloaded circuit may not always trip circuit breaker. Reduced voltage to a machine on an overloaded circuit will prevent components from operating properly.

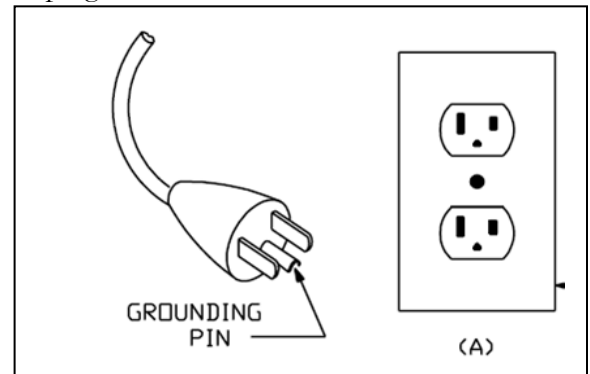

NOTICE

This machine must be protected from conditions which may damage the pump, tank, hoses and other components.

- **Freezing of water in this machine will cause serious damage.** The Defender 500, solution hoses, and tools must be protected from freezing temperature. Store, transport, and use this equipment only in temperatures well above freezing. (32°F or 0°C). If you suspect the Defender 500 has been frozen, do not plug in or turn on machine until you are sure it has thawed completely.
- If the equipment cannot be stored or transported in a warm environment, it can be guarded from freezing by running an anti-freeze solution through the incoming water lines, solution pump, solution lines, tools.
 - The anti-freeze solution must be completely flushed from the machine before it is returned to service.
- The Defender 500 must not be used to pick up flammable or combustible materials or used in areas where these materials may be present.
- Solvent-based or water-based solutions containing solvents may damage the pump, hoses, and other components. Do not assume chemical compatibility. Contact your distributor or Esteam Mfg if you have questions regarding the compatibility of your chemicals with the machine.
- Do not clean with solutions that are at temperatures above 130°F.
- Rinse the solution tank, chemical system, and pump with fresh water after each day's use.
- Do not allow pump to run dry. Always maintain adequate solution level to supply solution pump.
- HP hoses may rupture if worn or damaged. Do not use HP solution hoses if hose covering is cut, bulging, or otherwise damaged. Examine HP solution hoses daily and replace or repair hoses as needed.
- Use a Hydro-Filter II and clean the recovery tank daily to keep pump-out filter and pump from becoming clogged. Store the Defender 500 with the recovery tank lid open.
- Keep Vacuum Inlet Filter clean and check float for proper operation. Do not operate the Defender 500 without the Vacuum Inlet Filter in place. **Use defoamer to eliminate foam build-up during cleaning and prevent foam/moisture from entering vacuums.**

WARNING

Use common sense to protect yourself and others while using this equipment.

- Keep pets and children away from the machine when in use.
- Keep all body parts, hair, and loose clothing away from openings and moving parts. Always wear appropriate work clothing and safety equipment when operating unit.
- Use extra care when cleaning on stairs. Wet carpet on stairs can be slippery.
- Do not move the DEFENDER 500 up or down stairs when tanks are full of water. Drain solution and recovery tanks, and secure base latches before moving unit up or down stairs. Lift using only the machine handles designed & designated for moving and lifting.
- Water may be spilled, drip, or be exhausted from vacuums during operation. Place unit in area where water will not cause damage or use drop cloth to protect surfaces.

Operation Procedures

Knowledge of the proper operation of the Defender 500 is required to ensure user safety and efficient performance of the extractor.

SET UP AND OPERATION

1. Insert electrical cords into 3 pin grounded outlets. Two cord machines maybe equipped with the **Optional** Circuit Indicator located above the Switch Plate. The electrical cords must be plugged into separate circuits. When this is achieved the green light will illuminate showing the machine is ready for operation.
2. We recommend the use of a Esteam liquid Defoamer, to prevent the machine from prematurely shutting off due to excess foam in the recovery tank. Turn on vacuum and pour approximately ¼ cup of Esteam Liquid Defoamer into the end of the vacuum hose.

500 PSI Plunger pump priming instructions:

- Fill freshwater tank
- Turn on vacuum
- Always release the pressure by depressing the prime valve prior to turning on the pump, to release head pressure and prevent blowing fuse or over amping the pump motor
- Turn on pump
- Cover vacuum barb on recovery tank
- Pull prime valve trigger for about 30 seconds
- Shut off pump and vacuum
- Connect hoses for cleaning and machine is ready to use.

TO USE YOUR DEFENDER HEATER:

- A. Hook the wand solution hose to the quick connect of your machine.
- B. Plug the heater power cord into a wall that is on a separate circuit from the other cord.
- C. Turn the heater switch on.
- D. When the red light goes out, the solution is heated and ready to use.

OPERATING INSTRUCTIONS (CONTINUED)

WARNING: If your heater does not work DO NOT attempt to repair it yourself, call your distributor for repair procedures. Using solvents in heaters can be hazardous and will void your warranty. Allowing heaters to freeze will crack the heater cartridge and will also void your warranty.

DANGER: No solvents of any type may be used in this system at any time. The use of solvents is extremely hazardous resulting in possible fire and/or explosion.

4. Connect vacuum and solution hoses to the carpet cleaning wand.
5. Proceed to clean carpets.
6. When the recovery tank becomes full, vacuum will automatically stop extracting. When vacuum stops extracting it will make a distinctive high pitched noise as all the air flow will be cut off. At this time switch unit off. Drain the recovery tank by pulling up on drain valve on front of machine

NOTE: Ensure that the high-water level float screen inside the recovery tank is free from any obstructions. Be sure to close drain valve before resuming cleaning.

7. To empty solution tank remove vacuum hose from wand. Turn on vacuum and extract solution from solution tank into recovery tank, then drain recovery tank.

NOTE: Do not completely submerge the end of vacuum hose into solution. Allow some air to enter end of vacuum hose with liquid.

8. When the job is completed, empty and rinse out the solution and recovery tanks. Allow vacuum to run for 3 to 5 minutes. This will eliminate all moisture from vacuum assuring long vacuum life.

WARNING: When using electrical equipment around water it is important to wear rubber soled shoes and keep machine properly grounded at all times. Failure to do so could result in electric shock.

MAINTENANCE

DAILY:

- Clean high water level float screen inside the recovery tank.
- Ensure high level float ball is working properly.
- Rinse out recovery tank after use.
- Clean dirt and obstructions from the (recovery tank) drain valve rubber gaskets to prevent premature wear.
- Rinse out pump with clean water at conclusion of workday.
- Clean poly housing with mild soap and water.

MONTHLY:

- Clean air inlet and check exhaust port.
- Check 1 ½ dump valve seal.

YEARLY:

- We recommend that your unit be inspected by a qualified service technician once a year.

PREVENTATIVE MAINTENANCE:

- Never store this unit in a place where there is a possibility of the temperature dropping below 0°C (32°F)

Accessory Storage Options:

The Defender 500 is designed to make it easier for the operator to transport the machine and the most common cleaning accessories.

Bucket & Sprayer Storage

The top of the Defender 500 is sized and recessed to hold a five-gallon bucket or two one-gallon chemical bottles as well as two 2QT sprayers.

Power Cord Storage

The back of the Defender 500 has two sets of cord wraps to hold two 12/3 x 25' power cords.

Carpet Wand Storage

The front of the Defender 500 is designed to hold a S-Bend Carpet wand and has two straps to hold it securely. Optional strap for larger wands available

Other Tool & Hose Storage

Each side of the Defender 500 has a set of molded in threaded inserts to which holders can be attached to hold other accessories or supplies making it much easier to move around. Four 1/4-20 x 5/8" mounting screws are required.



TROUBLE SHOOTING

WARNING: Prior to inspection or repair of this machine, disconnect all electrical cords rendering the machine powerless. Failure to do so could result in serious or fatal injury.

PROBLEM	CAUSE	SOLUTION
1. Entire unit will not operate	1. Unit not plugged in	1. Connect unit to 3 pin grounded outlets
	2. Loose wiring	2. See dealer
2. Pump will not run	1. Switch not turned on	1. Turn on switch
	2. Broken switch	2. See dealer
	3. Loose wiring	3. See dealer
	4. Pump motor defective	4. See dealer
3. Vacuum will not run	1. Switch not turned on	1. Turn on switch
	2. Broken switch	2. See dealer
	3. Loose wiring	3. See dealer
	5. Blocked rotor	5. See dealer
4. Pump runs but does not pump solution	1. Out of solution	1. Fill solution
	2. Pump inlet screen plugged	2. Clean inlet screen
	3. Pump was not properly primed	3. Prime pump using priming hose
	4. Kink in solution hose	4. Remove kink
	5. Plugged jet or quick connect	5. Remove blockage
	6. Internal (inside machine) or external solution line damaged and leaking	6. See dealer

TROUBLE SHOOTING (CONTINUED)

PROBLEM	CAUSE	SOLUTION
5. Pump runs but has loss pressure	1. Partial kink in solution hose	1. Remove kink
	2. Partial blockage in solution hose	2. Remove blockage
	3. Jet orifice opening on cleaning wand is too large	3. Total jet opening for 500 PSI pump should be .06 or .08. Heat option should be .03
	4. Internal pump components wearing out	4. See dealer
6. Vacuum operates but has poor or no suction	1. Recovery tank full	1. Drain recovery tank
	2. Vacuum hose plugged	2. Locate and remove blockage
	3. Wand plugged	3. Locate and remove blockage
	4. Exhaust port blocked	4. Locate and remove blockage
	5. High level float stuck in off position	5. Turn vacuum off and tap top of float screen cage
	6. Front drain valve left open after draining recovery tank	6. Close recovery tank drain valve on front of machine
7. Vacuum prematurely stops extracting	1. Excess foam in recovery tank	1. Add defoamer to recovery tank
	2. Lint or dirt on automatic shut off float screen	2. Clean auto shut off float screen
	3. Defective float ball	3. Replace float screen cage

TROUBLE SHOOTING (CONTINUED)

PROBLEM	CAUSE	SOLUTION
8. Machine spits water out of exhaust port	1. High level float not working properly	1. Check auto shut off float cage and ball for proper operation
9. Machine blowing excessive amounts of water out of exhaust ports	1. Damaged (leaking) recovery tank fittings	1. Immediately shut unit down. Bring unit to a dealer for service
10. Water accumulating in bottom electrical component area	1. Inside solution line leaking	1. Immediately shut unit down. Bring unit to a dealer for service
	2. Pump leaking	2. Immediately shut unit down. Bring unit to a dealer for service
	3. Solution or recovery tank leaking from above	3. Immediately shut unit down. Bring to a dealer for service
11. Heater won't work.	1. Heater cord not plugged in.	Connect cord to 3 Pin (Separate) outlet
	2. Faulty Thermostat or Thermo cut-out	See dealer
12. Water not hot enough	1. Check Jet size on wand or upholstery tool. Do not exceed .03 orifice size for maximum heat transfer	
	2. Do not use cold water in solution tank. Must use hot tap water for maximum heat transfer	

ESTEAM® CLEANING SYSTEMS

DEFENDER EXTRACTOR WARRANTY

NOTICE: REVIEW THIS WARRANTY CAREFULLY AS THIS DOCUMENT CONTAINS LIMITATIONS AND EXCLUSIONS.

PART I:

Esteam Manufacturing. (hereinafter referred to as "Esteam") warrants each new Defender Extractor, subject to the limitations as defined in the specific details of its warranty coverage defined below.

LIMITED HOUSING WARRANTY COVERAGE:

Esteam warrants the Defender Polyethylene Machine Housing Unit to be free from defects in material and workmanship (including cracking, leaking or deterioration) for three years, expressly subject to the limitations stated herein.

In the event a defect occurs in a Defender Housing Unit within three years of receipt by the original customer, Esteam will, if satisfied on its examination that the failure is due to defective material or workmanship, repair or replace the Defender Housing Unit, at no cost to the original customer, other than as maybe provided for in this warranty.

90 DAY LIMITED WARRANTY COVERAGE:

Esteam warrants all switches, vacuum hoses and solution hoses to be free from defects in material and workmanship, for any defect occurring within 90 days of receipt by the original customer of the Defender Extractor; and further subject to the limitations stated below. 90 day on labor, subject to Esteam's approval; hourly labor credit is set by Esteam.

12 MONTH WARRANTY COVERAGE:

Subject to the Limited Warranty and the 90 Day Limited Warranty; Esteam warrants all remaining items on the Defender Extractor to be free from defect in material or workmanship (excluding any labour charges) for a period of 12 months from date of receipt of the unit by the original customer; and further subject to the limitations stated below.

PART II - REPLACEMENT PARTS (UNDER WARRANTY)

Replacement warranty parts will be genuine Esteam parts, or parts of similar kind and quality.

All replacement warranty parts are warranted to be free from defects in materials or workmanship from the date of the original unit purchase for the balance of the original warranty period namely: 90 days, 12 months, or the Limited Warranty, whichever is applicable; all in accordance with the terms of Part I, of this warranty.

PART III - LIMITATIONS ON WARRANTY COVERAGE

WHAT IS NOT COVERED:

Notwithstanding any other term or covenant of Esteam contained herein, the following provisions shall apply:

- (i) No warranty is provided for any Esteam product which has failed as a result of freezing, fire, misuse, alteration, improper amps or voltage, accidental damage, improper maintenance, unauthorized repairs, alterations, abuse, neglect or operation of a Esteam product not expressly recommended or contemplated by Esteam; and
- (ii) No warranty is provided for mechanical or electrical breakdown caused by scale, hard water buildup, improper use of chemicals or resins, damage due to environmental conditions, and acts of God, or other events beyond the control of Esteam; and
- (iii) No warranty is provided for mechanical or electrical breakdown or failure of an Esteam product resulting from ordinary wear and tear, or the consequences thereof; including but not limited to the gradual reduction of the operating performance of the product. The determination of what is or is not ordinary wear and tear is at the sole discretion of Esteam; and
- (iv) No warranty is provided for damage caused by the failure of non-warranted parts and/or accessories, even if warranted parts are damaged as a result of the failure of a non-warranted part; and
- (v) No warranty is provided for damage resulting from failure by the customer to maintain scheduled maintenance requirements. The Esteam system has many parts which must either be replaced or checked for wear on a regular basis; including but not limited to replacement filters and lubricants. This system requires regular maintenance, service and attention by the customer; and
- (vi) No warranty is provided as to any extra expenses incurred by the customer, including but not limited to economic, incidental, consequential loss or damage (e.g. all labour charges, rental equipment, down time, lodging, commercial or business loss of any nature or kind due to product failure); whether direct or indirect, exemplary or punitive damage or loss, and whether in contract, tort or otherwise; and
- (vii) No warranty is provided as to failure of any cosmetic item or finish, labeling, silk screening, decals, paint, trim or other similar decorative items.
- (viii) Brass, rubber and synthetic rubber parts (e.g. "O" rings, diaphragms, gaskets, seals, grommets) are considered expendable in normal use, and are therefore not included in any warranty by Esteam.

PART IV - EXCLUSION OF LIABILITY

Esteam makes no warranties or representations, either expressed or implied, oral or written, in fact, or by operation of law, or otherwise, except as expressly stated herein as to the 90 day Limited, 12 month and Limited Extended

warranties. Esteam, its officers, directors, agents, dealers and its affiliates (and their respective officers, directors, agents and dealers) shall not be liable to the customer nor to any party for any liability, including without limitation, strict liability, liability for loss, injury or damage due directly or indirectly to the use or operation of the Esteam product; consequential, exemplary and/or punitive damage or loss, whether in contract, tort, or otherwise.

PART V - RETURN GUIDELINES

Defective items must be replaced through a local Esteam Distributor. Replacement parts will be sent via prepaid regular ground service to the distributor. The defective part must be returned F.O.B. factory within 30 days including a letter providing the machine's serial number, date of purchase, material return authorization number, and customer name. If applicable, credit will be issued after the item has been evaluated by Esteam. Failure to comply with return policy will void the warranty on that item.

PART VI - CREDIT POLICY

All customers purchasing parts through an Esteam distributor must arrange credit directly with that distributor.

PART VII - OUTSIDE SOURCE WARRANTY REPAIRS

At the sole discretion of Esteam, it may be necessary to perform warranty/repairs at an outside source. An estimate must be submitted to and approved by Esteam prior to work being performed. Failure to do so will result in denial of your warranty claim.

PART VIII - TRANSFERABILITY

This warranty is not transferable to any subsequent owner.

PART IX - NOTICE - CUSTOMER OBLIGATIONS

- (i) Your responsibility as a customer includes but is not limited to cleaning, lubricating, seasonal maintenance (e.g. winterizing), replacement of worn parts and all regular scheduled or unscheduled maintenance.
- (ii) Any claim for warranty must be presented to Esteam or its authorized dealer, prior to the expiration of the time limitations specified and not thereafter, otherwise any warranty is void.
- (iii) Notwithstanding the generality of the foregoing customer obligations, Esteam does hereby bring to the attention of the customer, these specific maintenance operating requirements of the Defender Extractor to validate its warranty:

(a) **Chemical Warning:**

Any improper use of chemicals shall void any Esteam warranty and thusly exclude any liability by Esteam. No dry cleaning chemical may be used in a Defender Extractor; - as any such use may result in fire or pump/motor damage. A defoamer solution must be used by customer to limit foaming in the recovery tank.

(b) **Vacuum Motors:**

Require use of a defoamer. A vacuum motor showing moisture contamination on interior components shall void any warranty by Esteam.

(c) Pumps:

All pumps require daily flushing with clean water after use.

(d) Internal Heatermate:

The internal heater must be flushed with clean water after every use. Any buildup of hard water deposits or chemical buildup within the internal heater will void any Esteam warranty thusly exclude any liability of Esteam.

The foregoing constitutes Esteam's entire warranty and no other warranty, liability, contingency or responsibility, direct, indirect, consequential or in any other way connected with the sale or operation of Esteam machines or chemical product is expressed or implied.

Defender Extractor Warranty
Esteam Manufacturing. 3750-19th Street NE
Calgary, AB T2E 6V2 1-800-653-8338

Ninja 500

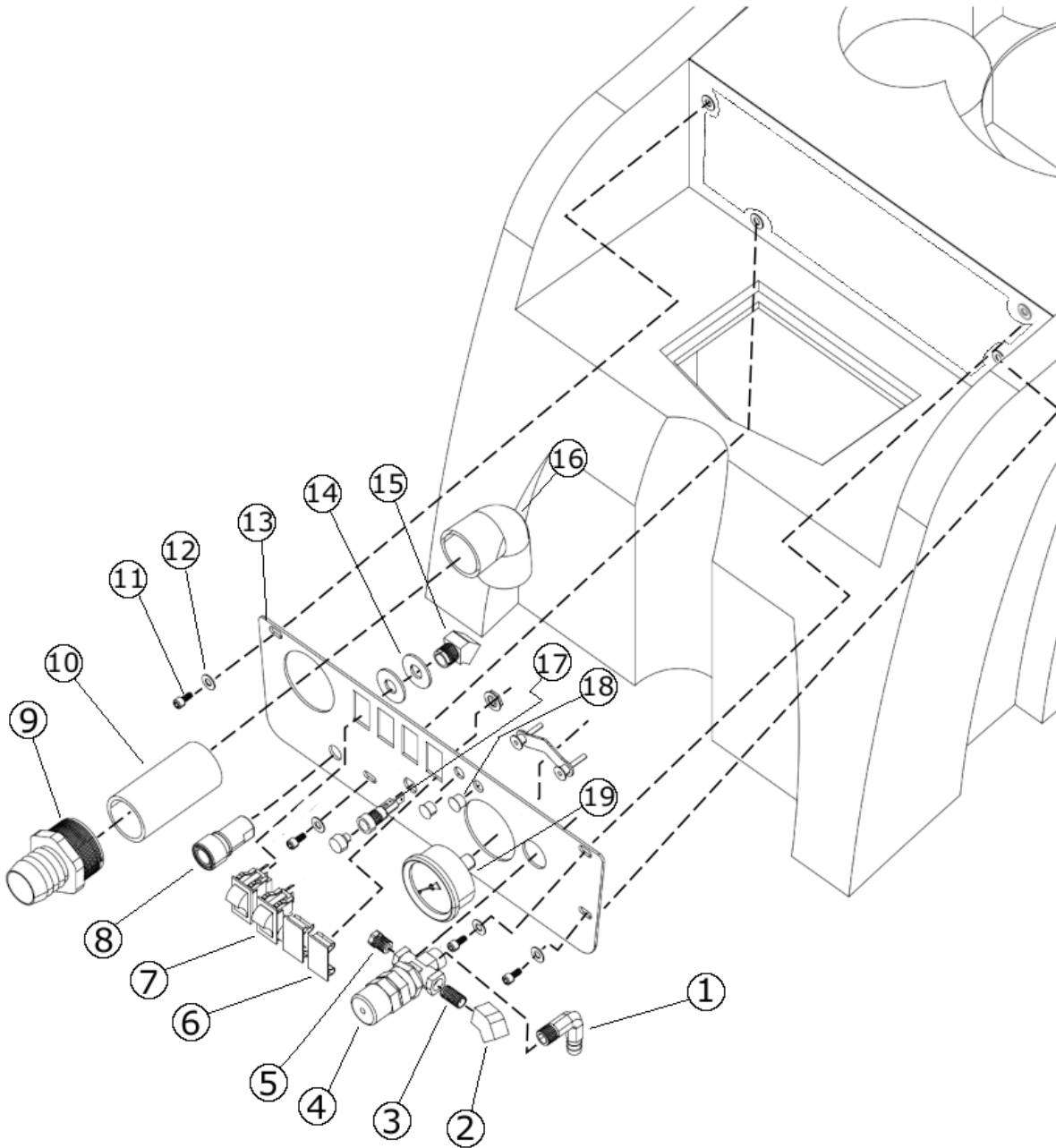

Ninja 500

REF	PART NO.	DISCRIPTION	NOTES
1	555-325	HOSE BARB 90, 1/2 BARB X 1/4 MPT	
2	555-182	ELBOW 45, 1/4" FEM. EXTRUDED	
3	555-073	CLOSE NIPPLE, 1/4 SS	
4	530-025	REGULATOR, 500 PSI	
5	555-452	PLUG, 1/4 MPT HEX	
6	305-015	FILL PLUG, PANEL	
7	305-085	SWITCH, ROCKER - WHITE	
8	580-010	Q.C. 1/4" FEM (CLOSED)	
9	590-425	PVC HOSE BARB, 1 1/2" HB X 2" MPT	
10	595-005	ABS PIPE, 1 1/2"	
11	410-415	CS, 1/4 X 20 X 1/2 SS SOC	
12	415-125	FW, 1/4 SS	
13	845-050	CONTROL PANEL. DEFENDER	
14	415-156	FW, 1/2 MILITARY 18.8 MS-819	
15	555-184	ELBOW 45, STREET 1/4"	
16	590-010	PVC ELBOW 1 1/4" 90, S x S	
17	345-005	FUSE HOLDER PANEL	
18	498-055	PLUG, 1/2" NYLON	
19	360-017	GUAGE, 1500 PSI ESTEAM	

Ninja 500

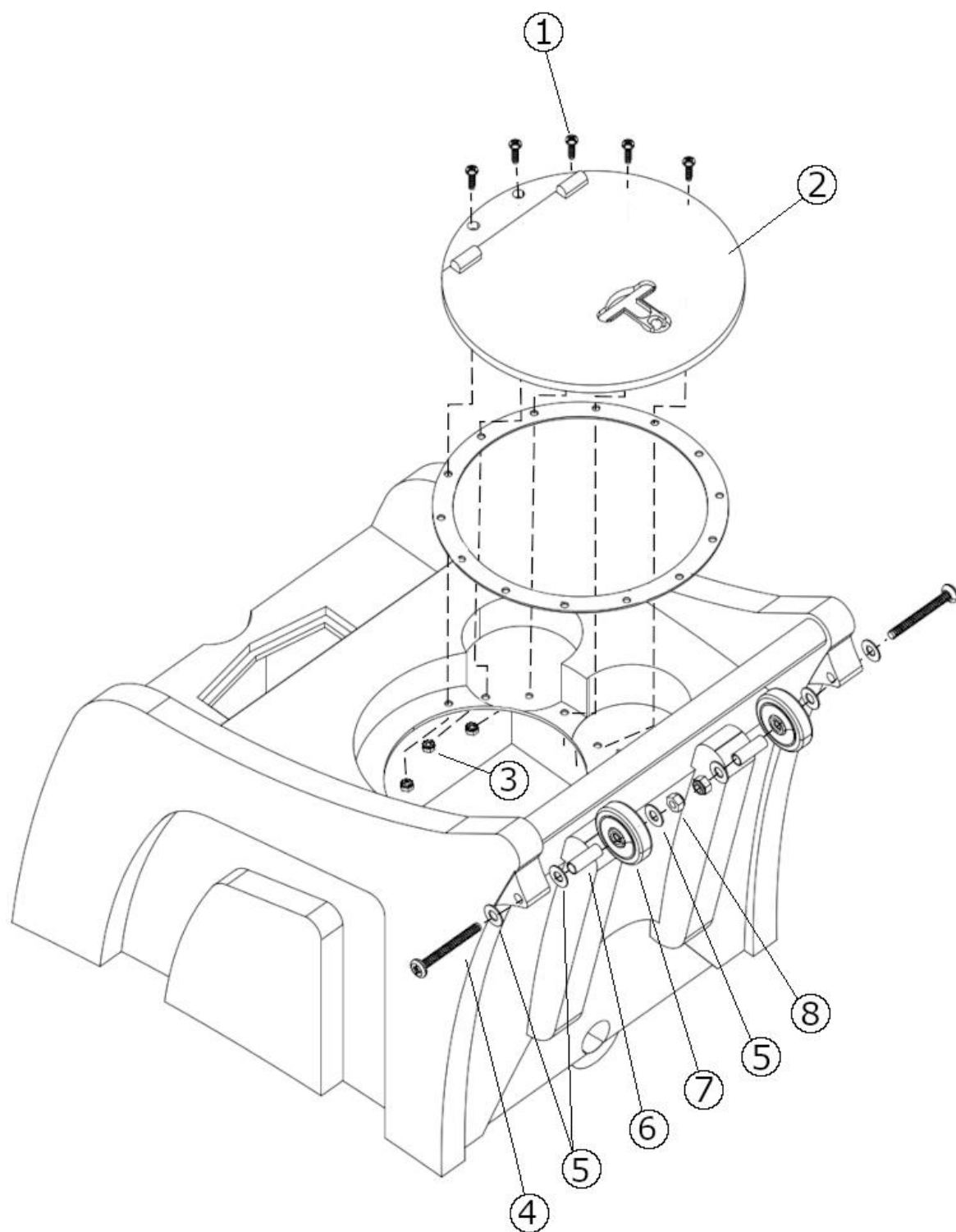

Ninja 500

REF	PART NO.	DISCRIPTION	NOTES
1	410-160	MS, 10-24 X 3/4 PAN PH SS	
2	585-220	LID ASSY 8"	
3	400-039	NUT, 10-24 K-LOK	
4	410-265	MS, 5/16 X 2 1/2 PAN PHIL SS	
5	415-128	FW, 5/16 SS	
6	355-230	VAC SPACER, 1 1/8"	
7	455-070	WHEEL, 3" DIA CUSHION RUBBER	
8	400-116	LOCKNUT, 5/16 x 18 NYLON SS	

Ninja 500

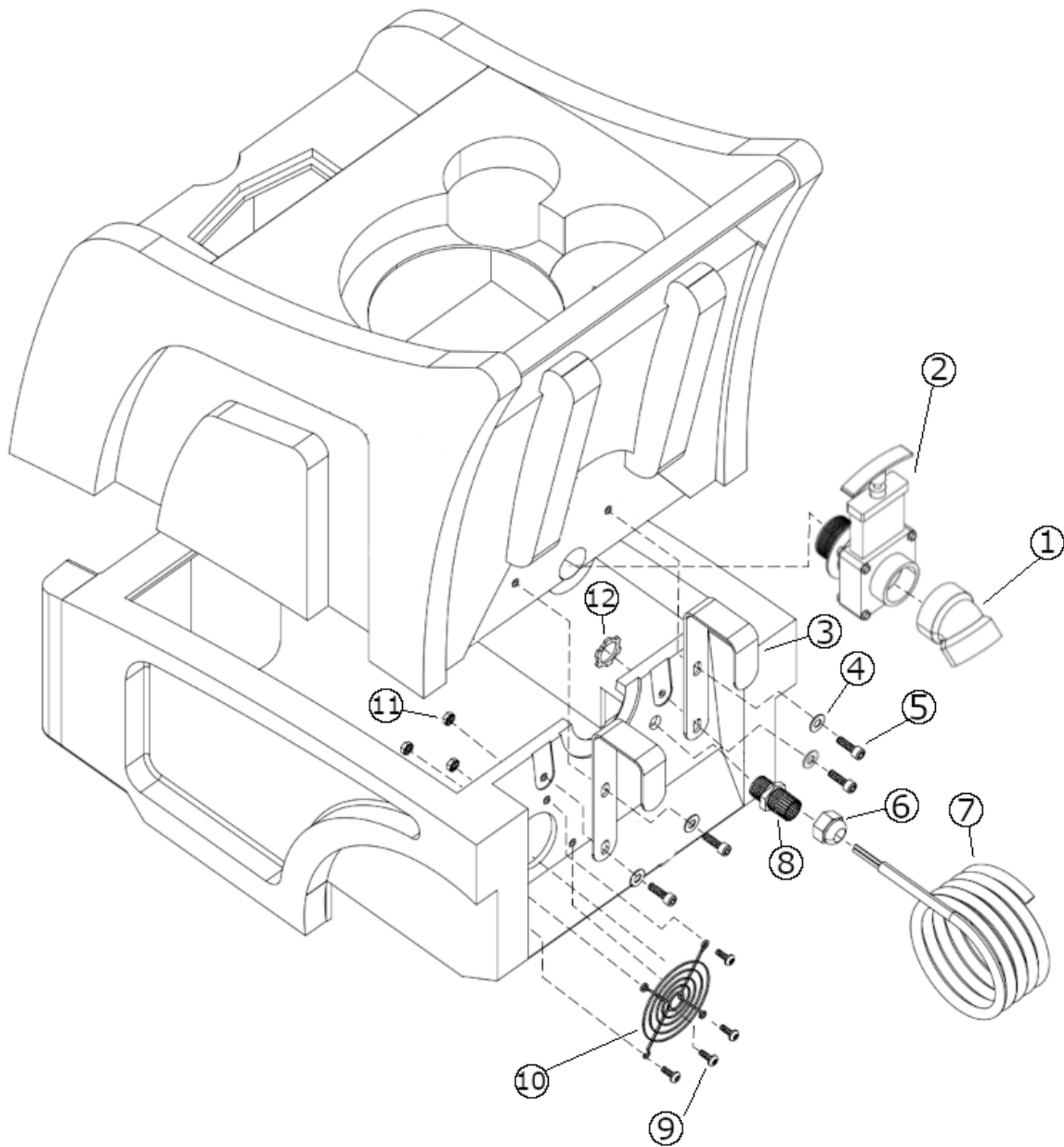

Ninja 500

REF	PART NO.	DISCRIPTION	NOTES
1	588-020	ABS ELBOW 45, 1 1/2" SLP X SLP	
2	545-100	.DUMP VALVE, 1 1/2" (FLANGE-MPT)	
3	465-075	POWER CORD , BRACKET	
4	415-125	FW, 1/4 SS	
5	410-410	CS, 1/4-20 X 3/4 SOC S/S	
6	335-015	STRAIN RELIEF, 14 GAUGE	
7	315-015	CORD, 25' BLACK 14/3 SJTW-A	
8	335-015	STRAIN RELIEF, 14 GAUGE	
9	410-205	MS, 10-32 X 1/2 PANPHIL SS	
10	560-325	GUARD, FINGER - 4" MUFFIN FAN	
11	400-043	NUT, 10-32 KEPS LOCKNUT	
12	400-165	LOCKNUT, 1/2" STEEL / STRAIN RELIEF	

Ninja 500

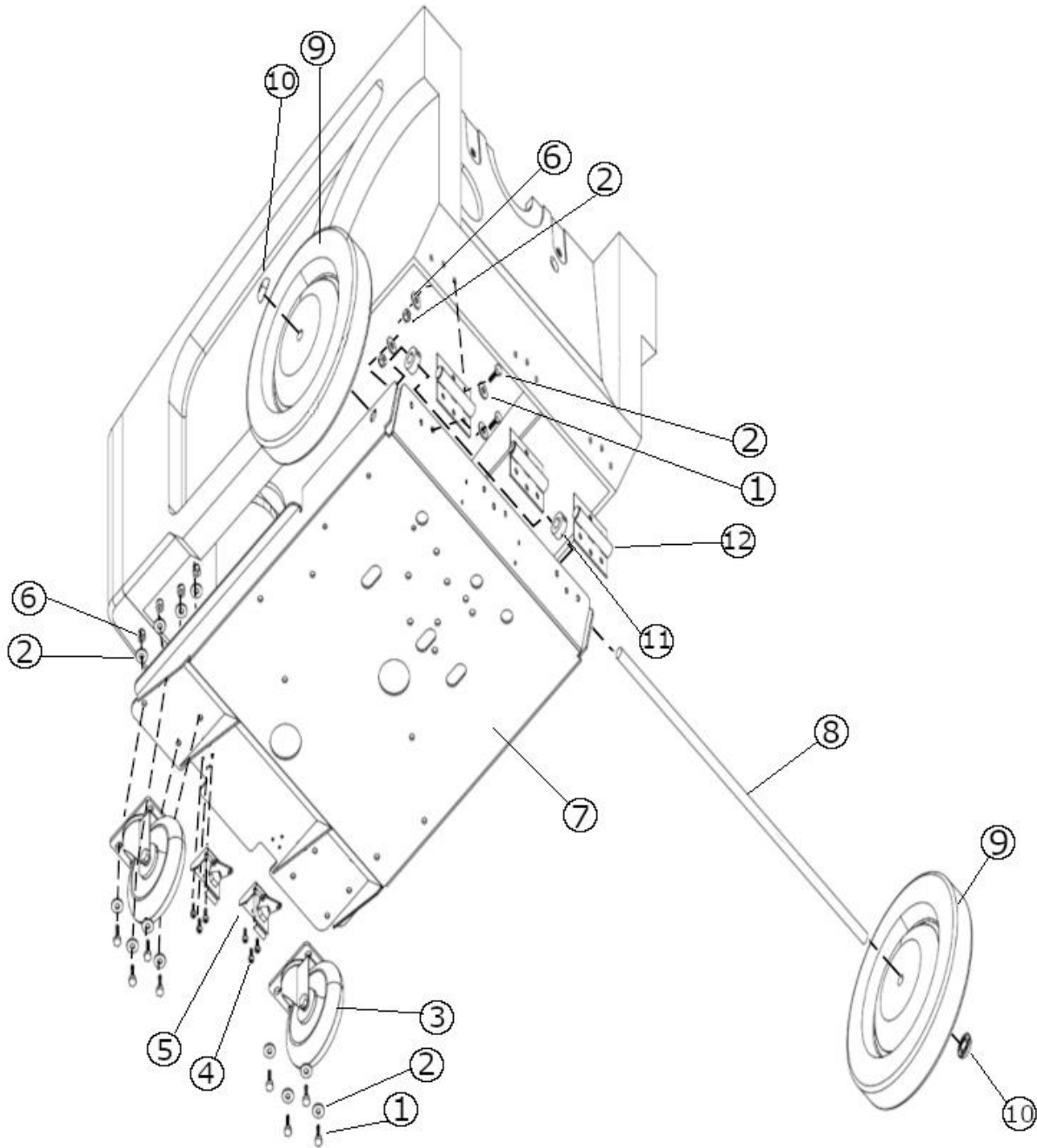

Ninja 500

REF	PART NO.	DISCRIPTION	NOTES
1	415-120	FW, 1/4 ZINC	
2	405-620	BOLT, 1/4X3/4 SS(HEX HD)	
3	455-006	CASTER, 5" SWIVEL	
4	410-205	MS, 10-32 X 1/2 PANPHIL SS	
5	445-012	LATCH	
5A	445-013	KEEPER	Not Shown
6	400-135	LOCKNUT, 1/4 X 20 NYLON ZINC	
7	845-095	PLATE, BASE, DEFENDER	
8	470-065	AXLE, DEFENDER	
9	455-060	WHEEL, 10"	
10	455-052	WHEEL CAP DOME - 1/2" METAL	
11	385-050	COLLAR, 1/2" SHAFT - HM	
12	440-020	HINGE, DEFENDER, PAIR	

Ninja 500

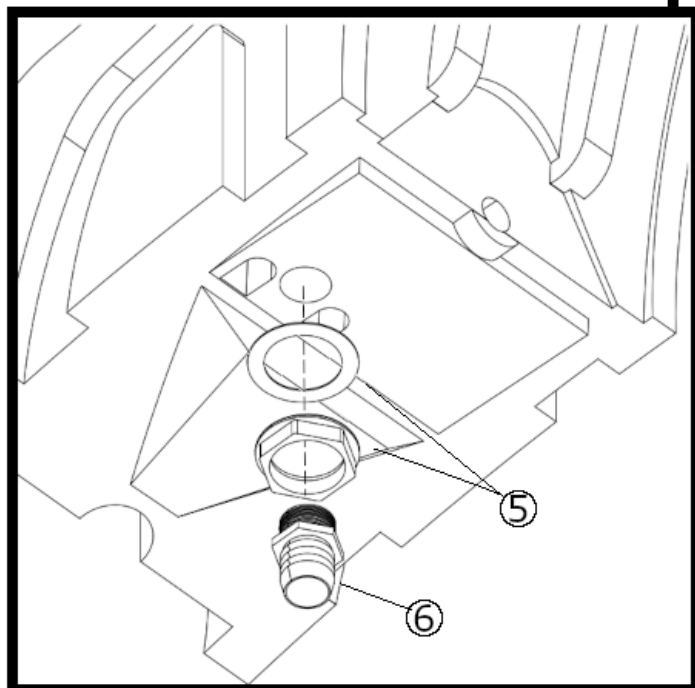
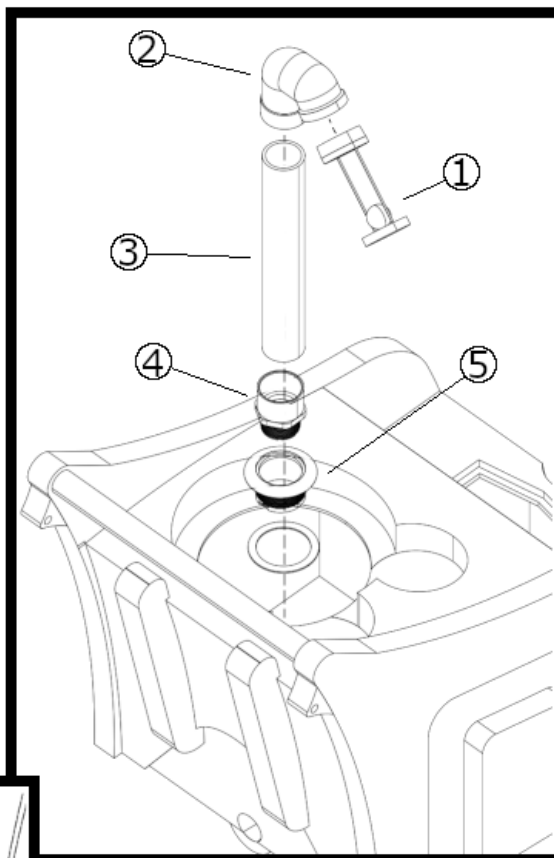

Ninja 500

REF	PART NO.	DISCRIPTION	NOTES
1	597-010	FLOAT SCREEN CAGE - 1 1/2	
2	597-061	ADPT (RM) 30 DEGREE, FLOAT SCREEN 1 1/2"	
3	595-005	ABS PIPE, 1 1/2"	
4	590-415	PVC ADPT 1 1/2", S x MPT	
5	590-205	PVC WALL FITTING, 1 1/2"	
6	590-405	PVC HOSE BARB 1 1/2" x MPT	

Ninja 500

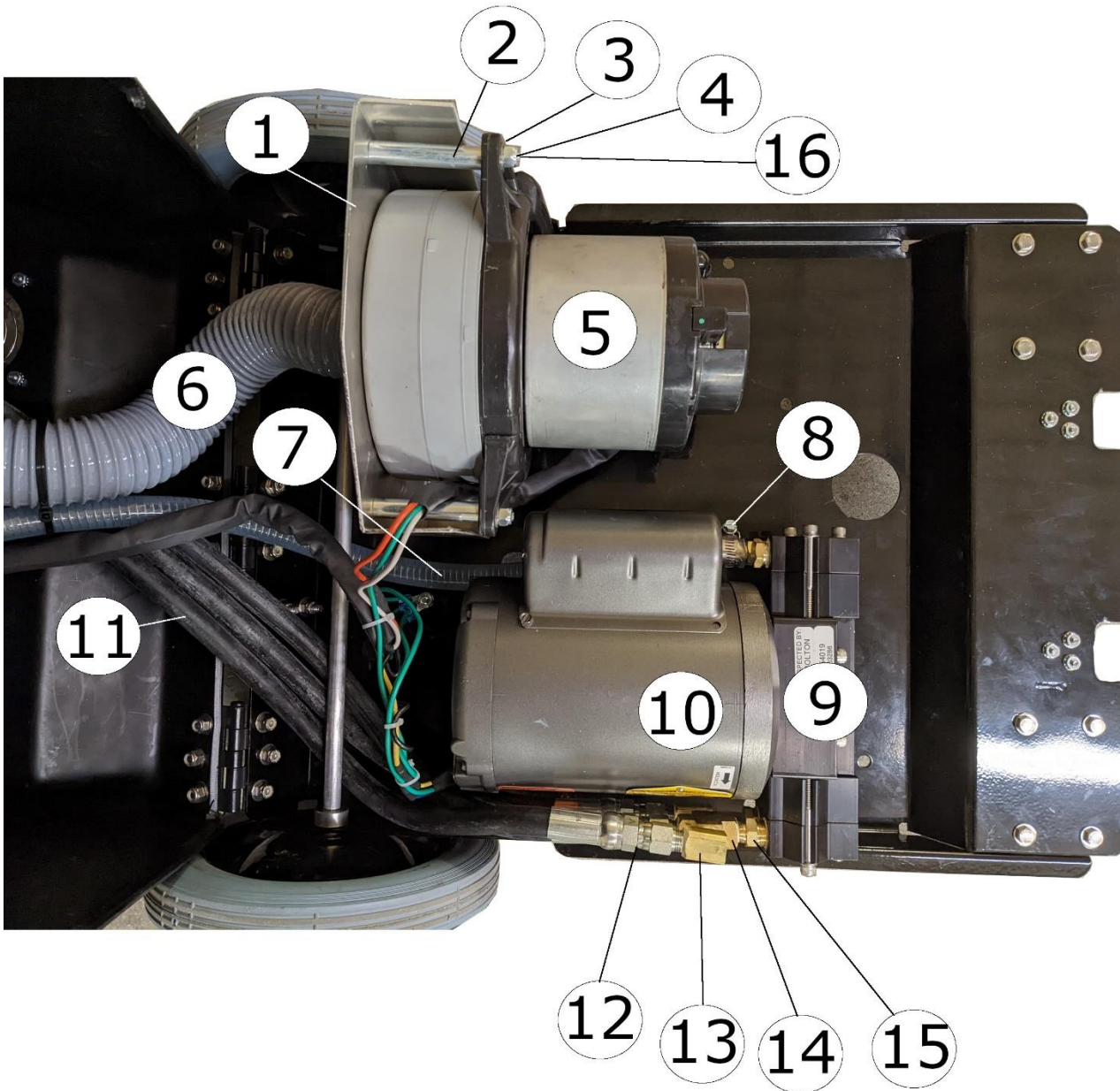

Ninja 500

REF	PART NO.	DISCRIPTION	NOTES
1	355-122	BRKT, VAC MOTOR 355-120	
2	355-225	VAC SPACER, 3/8 OD X 2 1/2 ID	
3	415-120	FW, 1/4 ZINC	
4	400-135	LOCKNUT, 1/4 X 20 NYLON ZINC	
5	355-120	VACUUM, 3-STG (117507-13) (LRG-PLASTIC)	
6	570-020	VAC HOSE, 2" WIRE REINFORCED	
7	572-155	POLYSPRING HOSE, 1/2"	
7A	355-121	VAC ADAPTOR FOR 355-120	NOT SHOWN
8	425-005	CLAMP, #8 HOSE 1/2 x 1	
9	512-585	PUMP 500 - 207V	
10	512-551	MOTOR, MODEL M110	
10A	512-542	PUMP, 500 (207) & M110 MOTOR	NOT SHOWN
11	572-125	PULSE HOSE, 3/8"	
12	581-065	CRIMP FTNG, 3/8" PULSE HOSE 1/4 MPT SVL	
13	555-206	ELBOW 90, 1/4" FPT. EXTRUDED	
14	555-922	EXTRUDED CROSS, 1/4"	
15	555-542	REDUCING NIPPLE, 3/8 MPT X 1/4 MPT	
16	405-065	BOLT, 1/4 X 6 RH STOVE ZINC(ALL THREAD)	

Ninja 500 With Heat

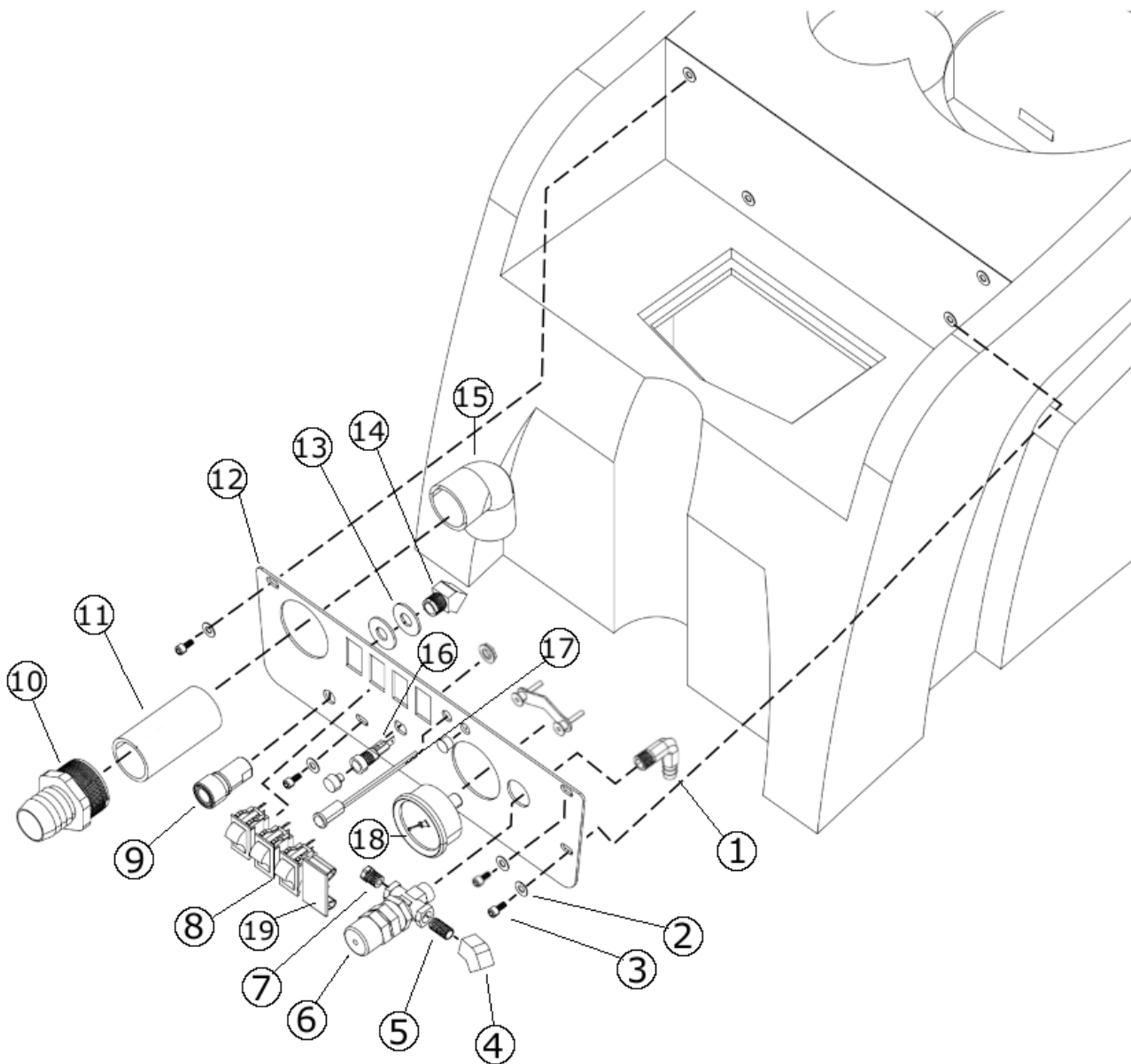

Ninja 500 With Heat

REF	PART NO.	DISCRIPTION	NOTES
1	555-325	HOSE BARB 90, 1/2 BARB X 1/4 MPT	
2	415-125	FW, 1/4 SS	
3	410-415	CS, 1/4 X 20 X 1/2 SS SOC	
4	555-182	ELBOW 45, 1/4" FEM. EXTRUDED	
5	555-073	CLOSE NIPPLE, 1/4 SS	
6	530-025	REGULATOR, 500 PSI	
7	555-452	REDUCING NIPPLE, 3/8 MPT X 1/4 MPT	
8	305-085	SWITCH, ROCKER - WHITE	
9	580-010	Q.C. 1/4" FEM (CLOSED)	
10	590-425	PVC HOSE BARB, 1 1/2" HB X 2" MPT	
11	595-005	ABS PIPE, 1 1/2"	
12	845-050	CONTROL PANEL. DEFENDER	
13	415-156	FW, 1/2 MILITARY 18.8 MS-819	
14	555-184	ELBOW 45, STREET 1/4"	
15	590-010	PVC ELBOW 1 1/4" 90, S x S	
16	345-005	FUSE HOLDER PANEL	
17	320-110	LAMP, PANEL (RED) 110V	
18	360-017	GUAGE, 1500 PSI ESTEAM	
19	305-015	FILL PLUG, PANEL	

Ninja 500 With Heat

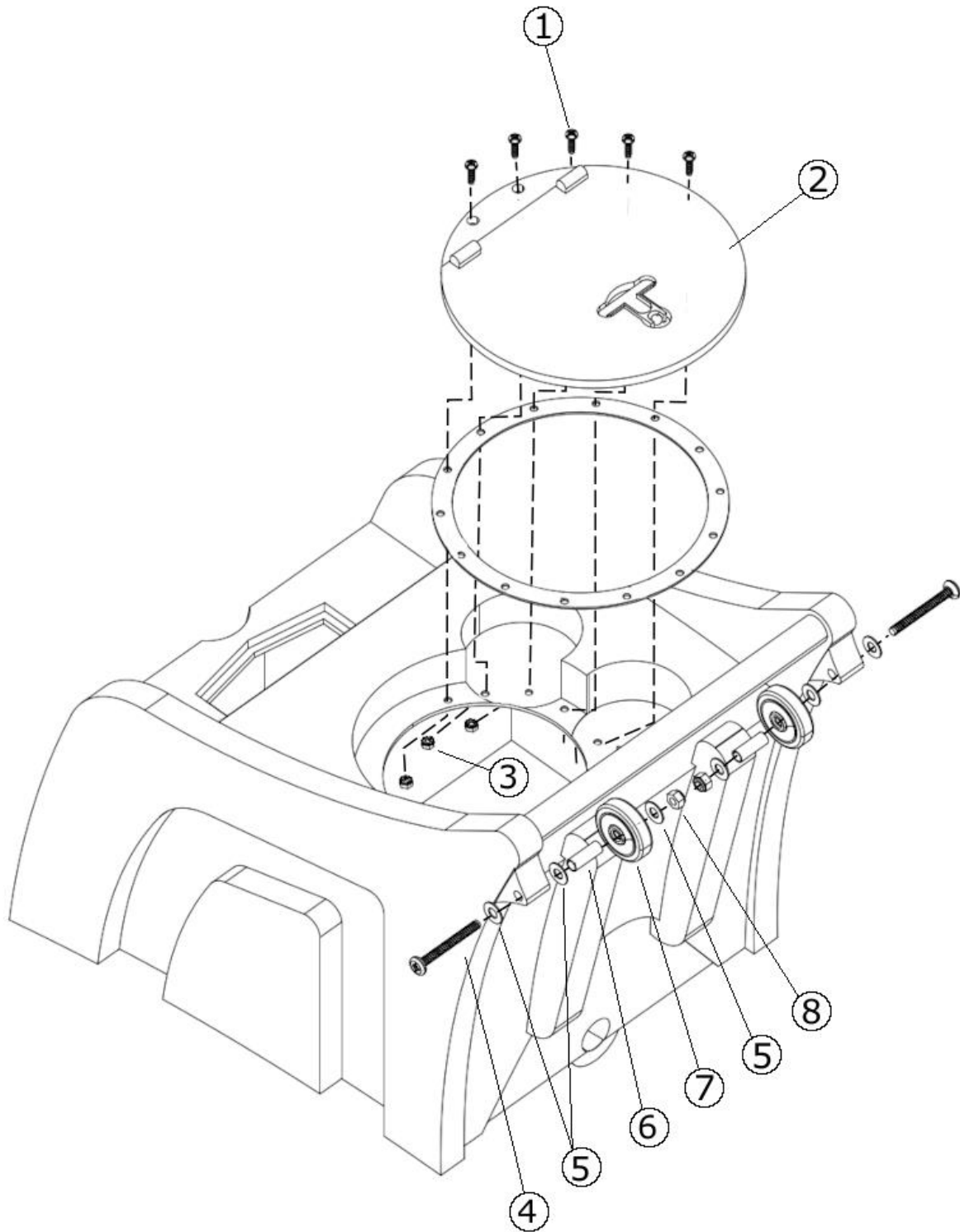

Ninja 500 With Heat

REF	PART NO.	DISCRIPTION	NOTES
1	410-160	MS, 10-24 X 3/4 PAN PH SS	
2	585-220	LID ASSY 8"	
3	400-039	NUT, 10-24 K-LOK	
4	410-265	MS, 5/16 X 2 1/2 PAN PHIL SS	
5	415-128	FW, 5/16 SS	
6	355-230	VAC SPACER, 1 1/8"	
7	455-070	WHEEL, 3" DIA CUSHION RUBBER	
8	400-116	LOCKNUT, 5/16 x 18 NYLON SS	

Ninja 500 With Heat

REF	PART NO.	DISCRIPTION	NOTES
1	588-020	ABS ELBOW 45, 1 1/2" SLP X SLP	
2	545-100	.DUMP VALVE, 1 1/2" (FLANGE-MPT)	
3	465-075	POWER CORD , BRACKET	
4	415-125	FW, 1/4 SS	
5	410-410	CS, 1/4-20 X 3/4 SOC S/S	
6	335-015	STRAIN RELIEF, 14 GAUGE	
7	315-015	CORD, 25' BLACK 14/3 SJTW-A	
8	335-015	STRAIN RELIEF, 14 GAUGE	
9	410-205	MS, 10-32 X 1/2 PANPHIL SS	
10	560-325	GUARD, FINGER - 4" MUFFIN FAN	
11	400-043	NUT, 10-32 KEPS LOCKNUT	
12	400-165	LOCKNUT, 1/2" STEEL / STRAIN RELIEF	

Ninja 500 With Heat

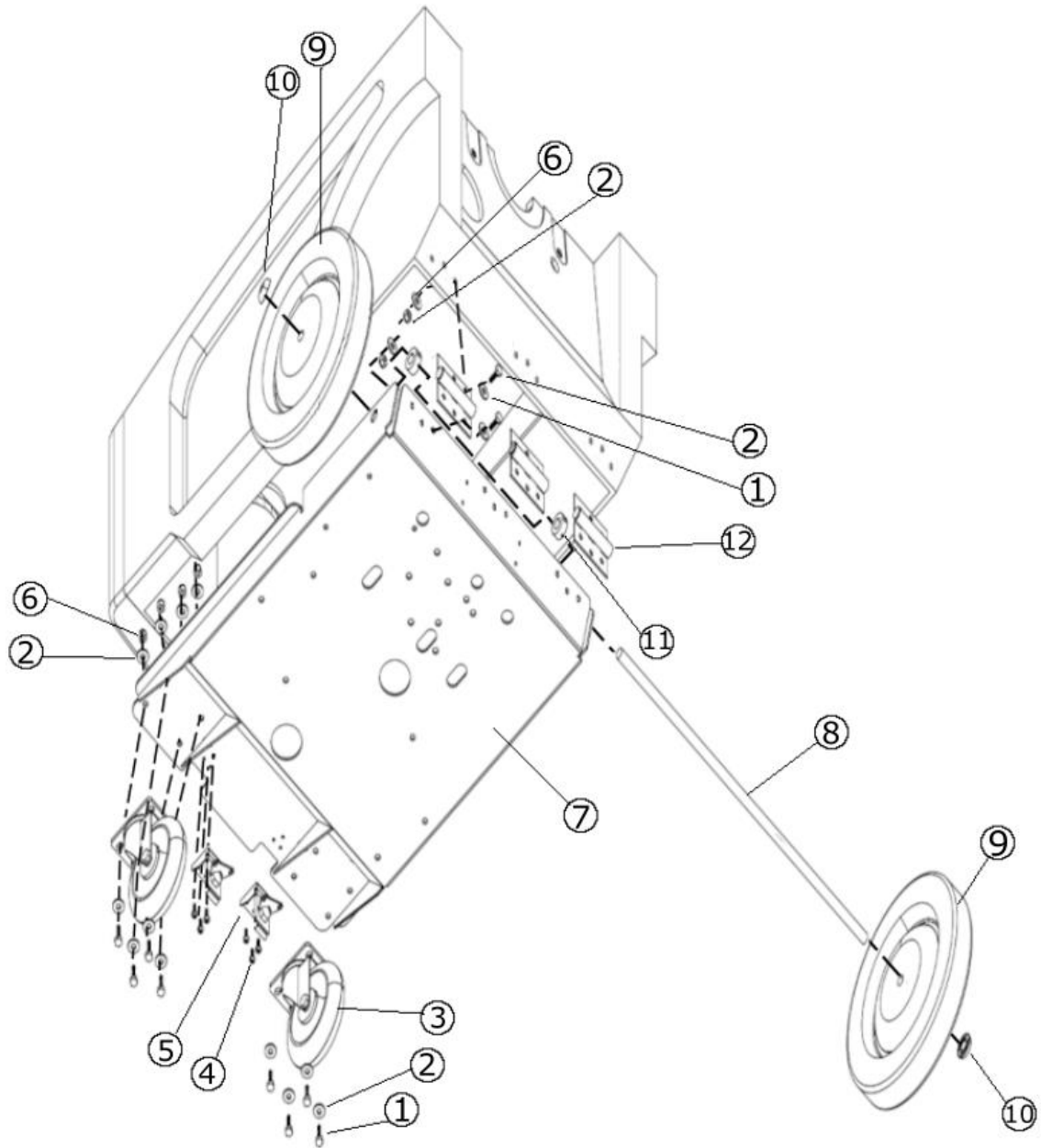

Ninja 500 With Heat

REF	PART NO.	DISCRIPTION	NOTES
1	415-120	FW, 1/4 ZINC	
2	405-620	BOLT, 1/4X3/4 SS(HEX HD)	
3	455-006	CASTER, 5" SWIVEL	
4	410-205	MS, 10-32 X 1/2 PANPHIL SS	
5	445-012	LATCH	
5A	445-013	KEEPER	Not Shown
6	400-135	LOCKNUT, 1/4 X 20 NYLON ZINC	
7	845-095	PLATE, BASE, DEFENDER	
8	470-065	AXLE, DEFENDER	
9	455-060	WHEEL, 10"	
10	455-052	WHEEL CAP DOME - 1/2" METAL	
11	385-050	COLLAR, 1/2" SHAFT - HM	
12	440-020	HINGE, DEFENDER, PAIR	

Ninja 500 With Heat

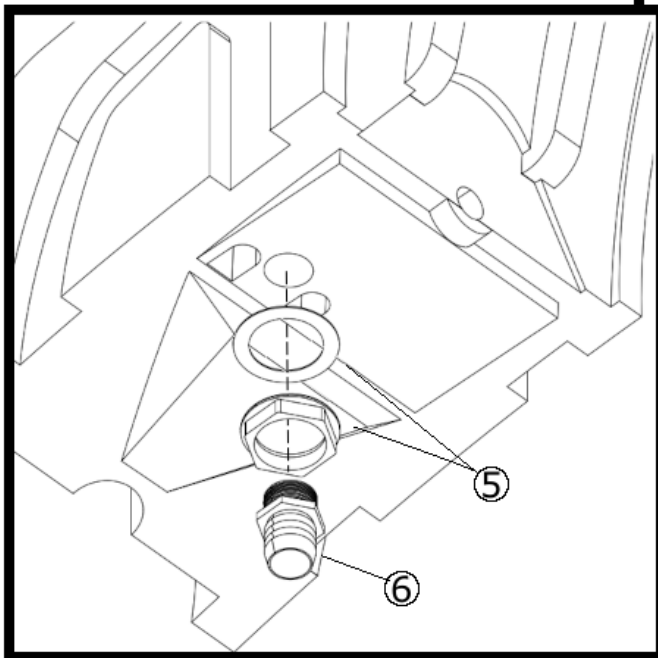
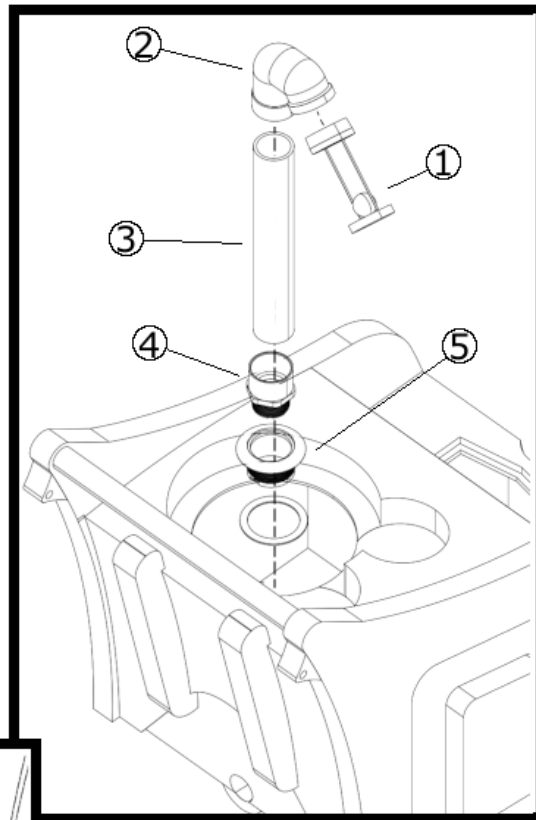

Ninja 500 With Heat

REF	PART NO.	DISCRIPTION	NOTES
1	597-010	FLOAT SCREEN CAGE - 1 1/2	
2	597-061	ADPT (RM) 30 DEGREE, FLOAT SCREEN 1 1/2"	
3	595-005	ABS PIPE, 1 1/2"	
4	590-415	PVC ADPT 1 1/2", S x MPT	
5	590-205	PVC WALL FITTING, 1 1/2"	
6	590-405	PVC HOSE BARB 1 1/2" x MPT	

Ninja 500 With Heat

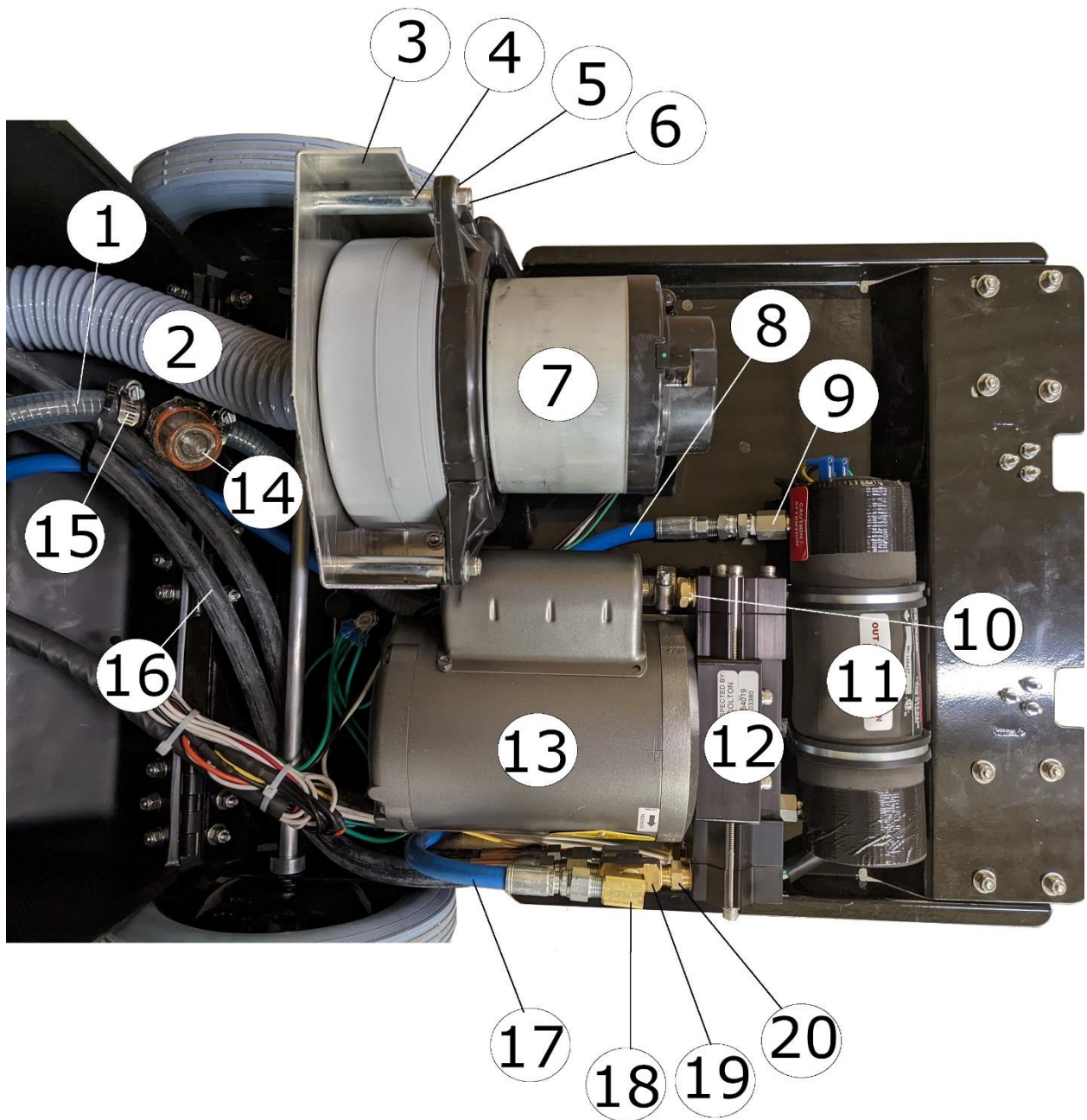

Ninja 500 With Heat

REF	PART NO.	DISCRIPTION	NOTES
1	572-155	POLYSPRING HOSE, 1/2"	
2	570-020	VAC HOSE, 2" WIRE REINFORCED	
3	355-122	BRKT, VAC MOTOR 355-120	
4	355-225	VAC SPACER, 3/8 OD X 2 1/2 ID	
5	415-120	FW, 1/4 ZINC	
6	400-135	LOCKNUT, 1/4 X 20 NYLON ZINC	
7	355-120	VACUUM, 3-STG (117507-13) (LRG-PLASTIC)	
8	263-012	HP HOSE,48" x 1/4" SWV X 1/4" HOSE	
9	555-003	ADAPTOR, SS, 1/4 X 1/4	
10	555-454	REDUCING NIPPLE, 3/4 MPT X 1/2 MPT	
11	490-005	FOAMED CASING, ROUND 1850W - HM	
12	512-585	PUMP 500 - 207V	
13	512-551	MOTOR, MODEL M110	
13A	512-542	PUMP, 500 (207) & M110 MOTOR	NOT SHOWN
14	560-116	STRAINER, INLINE BARBED 1/2"	
15	425-005	CLAMP, #8 HOSE 1/2 x 1	
16	572-125	PULSE HOSE, 3/8"	
17	263-007	HP HOSE,10 "-1/4 MPT SWV X 1/4 HOSE	
18	555-208	ELBOW 90, 1/4" STREET EXTRUDED	
19	555-922	EXTRUDED CROSS, 1/4"	
20	555-542	REDUCING NIPPLE, 3/8 MPT X 1/4 MPT	
21	581-065	CRIMP FTNG, 3/8" PULSE HOSE 1/4 MPT SVL	(FOR PULSE HOSE)

INTERNAL HEATER MATE

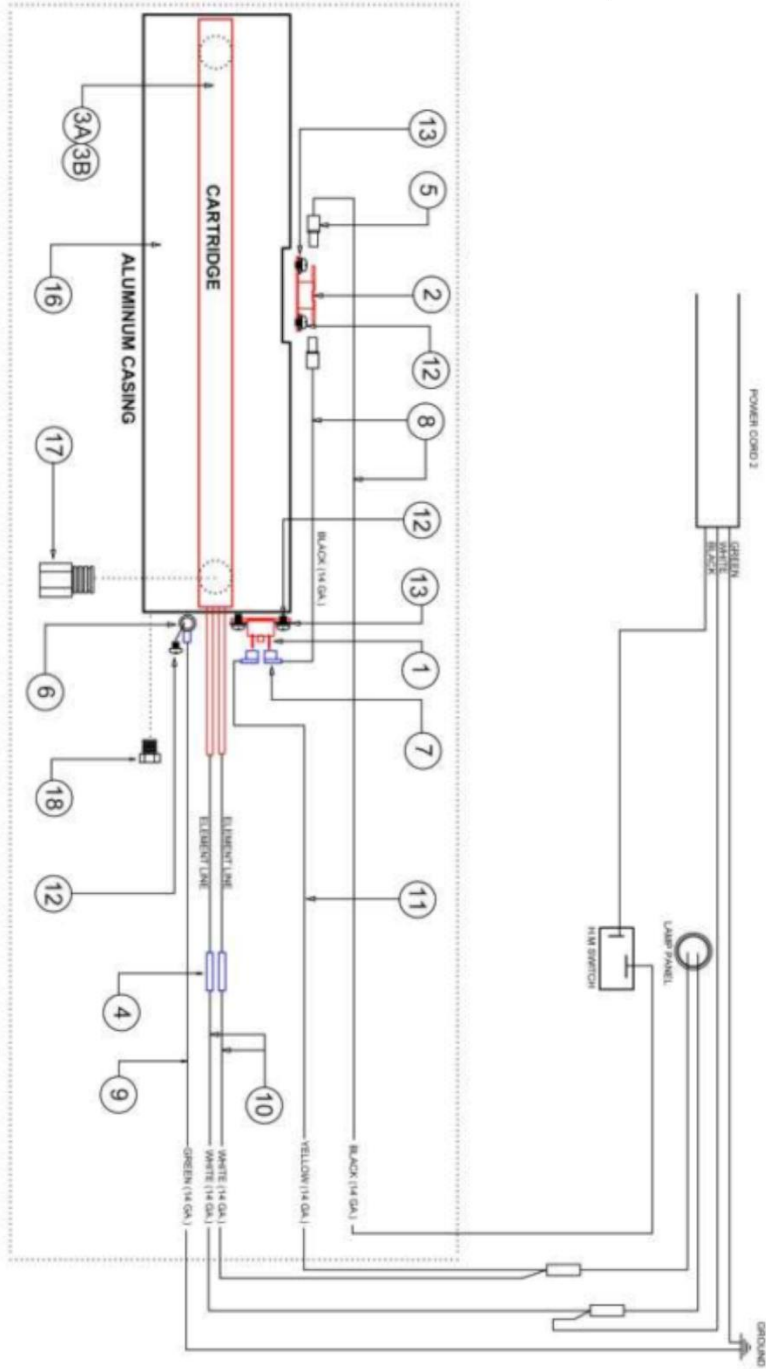

INTERNAL HEATER MATE (490-005/490-006)

REF	PART NO.	DESCRIPTION	NOTES:
1	305-245	Thermo Cut-Out	
2	305-265	Thermostat 200F	
3A	318-005	Heater Element 1850W 110V	Use For 490-005
3B	318-900	Heater Element 1850W 220V	Use For 490-006
4	325-005	Connector, Butt - Blue	
5	325-120	Spade, 3/16 F - Blue	
6	325-230	Terminal Ring, #10 - Blue	
7	325-500	Spade, 1/4 FEM. 90 Crimp	
8	330-225	Wire, 14 GA - Black	
9	330-230	Wire, 14 GA - Green	
10	330-235	Wire, 14 GA - White	
11	330-240	Wire, 14 GA - Yellow	
12	410-070	MS, 6 x 3/16 Pan PHL	
13	415-005	LW, 6 Zinc	
14	475-045	Gasket, 3" RND	Not Shown
15	475-070	Gasket 1/8"	Not shown
16	490-016	Alum (Round) Casing	
17	555-002	ADPT, 1/4 M x 1/4 F	
18	555-451	Plug, 1/8 Hex	

Ninja 500 2 – 3 Stage

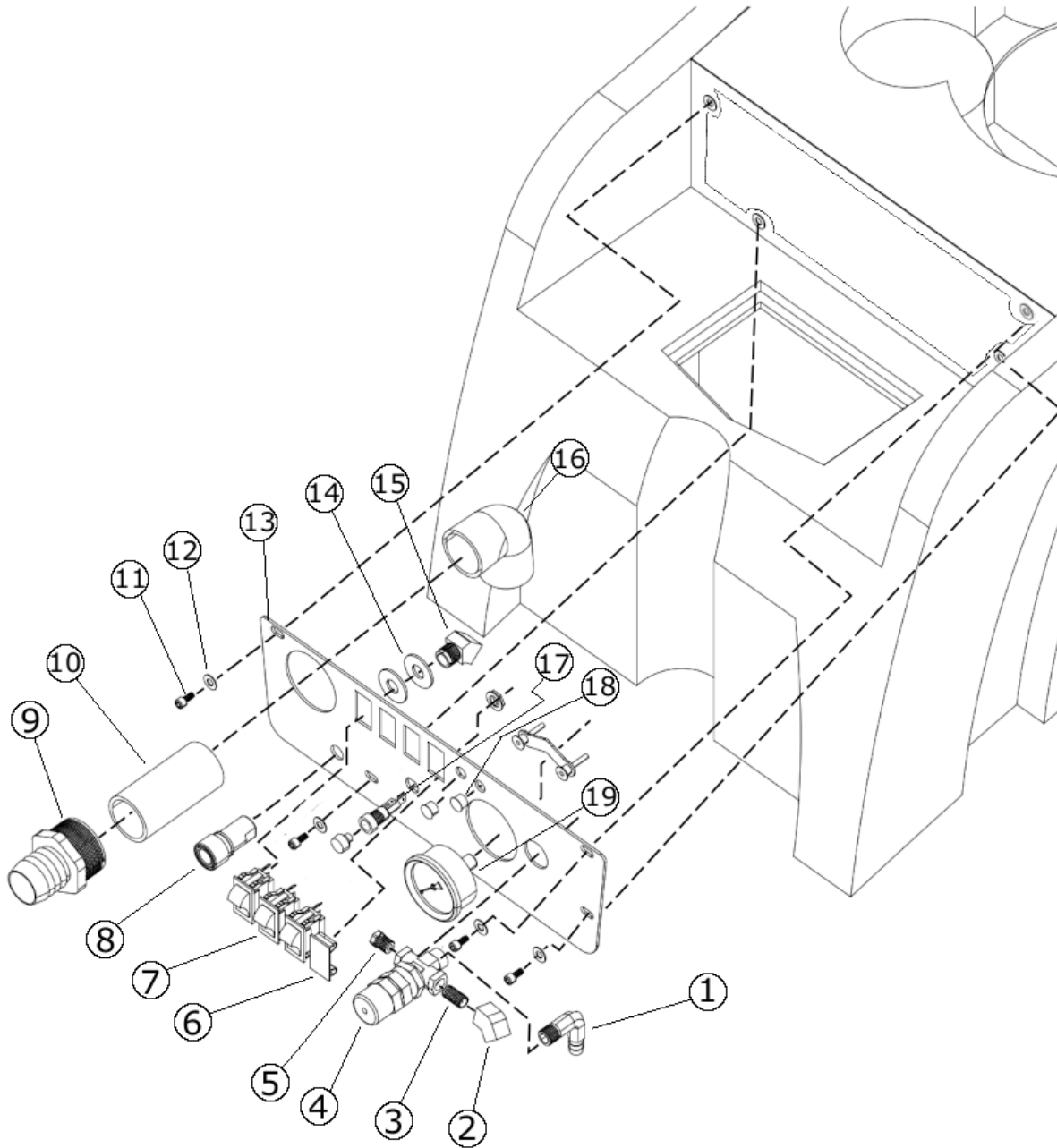

Ninja 500 2 – 3 Stage

REF	PART NO.	DISCRIPTION	NOTES
1	555-325	HOSE BARB 90, 1/2 BARB X 1/4 MPT	
2	555-182	ELBOW 45, 1/4" FEM. EXTRUDED	
3	555-073	CLOSE NIPPLE, 1/4 SS	
4	530-025	REGULATOR, 500 PSI	
5	555-452	PLUG, 1/4 MPT HEX	
6	305-015	FILL PLUG, PANEL	
7	305-085	SWITCH, ROCKER - WHITE	
8	580-010	Q.C. 1/4" FEM (CLOSED)	
9	590-425	PVC HOSE BARB, 1 1/2" HB X 2" MPT	
10	595-005	ABS PIPE, 1 1/2"	
11	410-415	CS, 1/4 X 20 X 1/2 SS SOC	
12	415-125	FW, 1/4 SS	
13	845-050	CONTROL PANEL. DEFENDER	
14	415-156	FW, 1/2 MILITARY 18.8 MS-819	
15	555-184	ELBOW 45, STREET 1/4"	
16	590-010	PVC ELBOW 1 1/4" 90, S x S	
17	345-005	FUSE HOLDER PANEL	
18	498-055	PLUG, 1/2" NYLON	
19	360-017	GUAGE, 1500 PSI ESTEAM	

Ninja 500 2 – 3 Stage

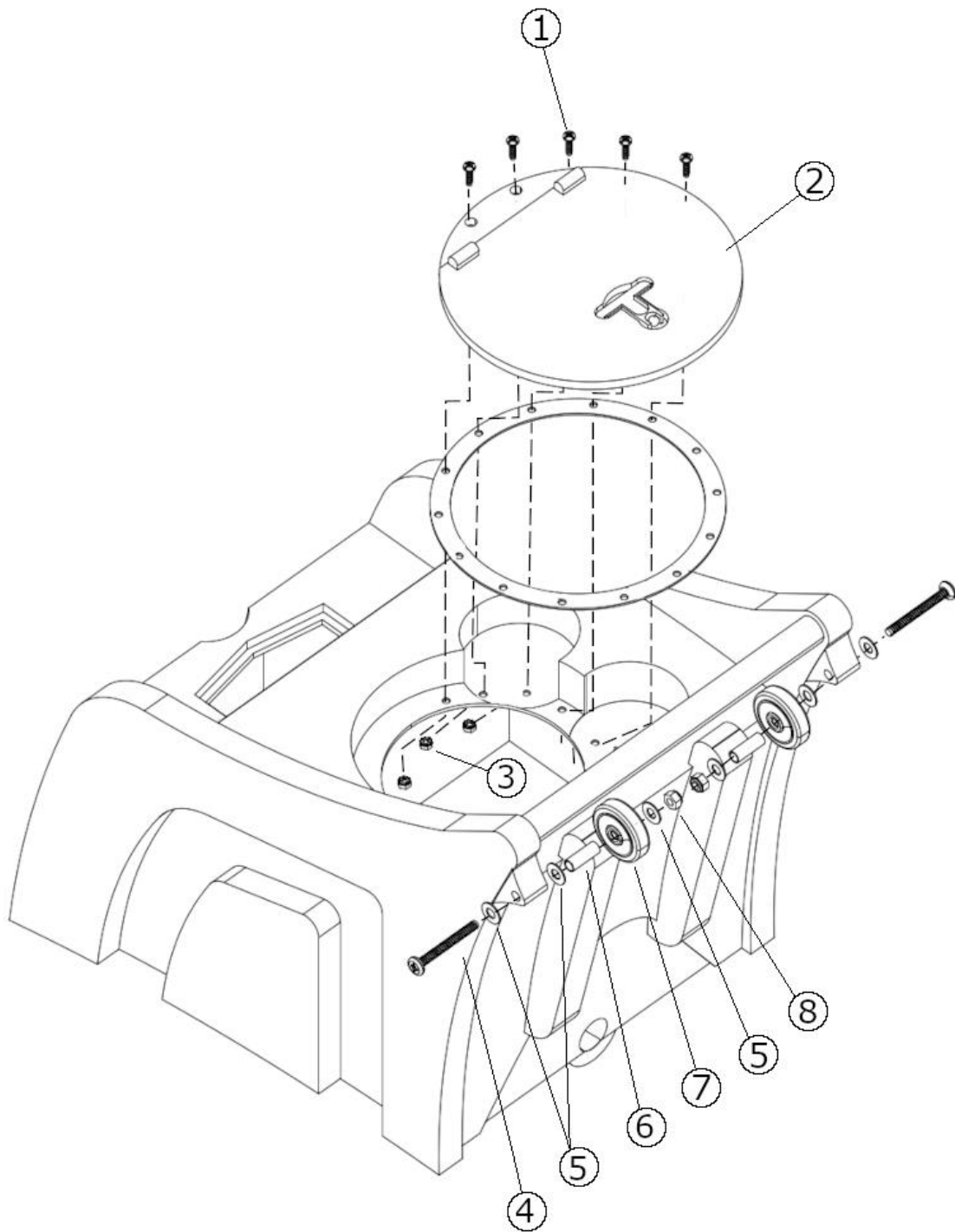

Ninja 500 2 – 3 Stage

REF	PART NO.	DISCRIPTION	NOTES
1	410-160	MS, 10-24 X 3/4 PAN PH SS	
2	585-220	LID ASSY 8"	
3	400-039	NUT, 10-24 K-LOK	
4	410-265	MS, 5/16 X 2 1/2 PAN PHIL SS	
5	415-128	FW, 5/16 SS	
6	355-230	VAC SPACER, 1 1/8"	
7	455-070	WHEEL, 3" DIA CUSHION RUBBER	
8	400-116	LOCKNUT, 5/16 x 18 NYLON SS	

Ninja 500 2 – 3 Stage

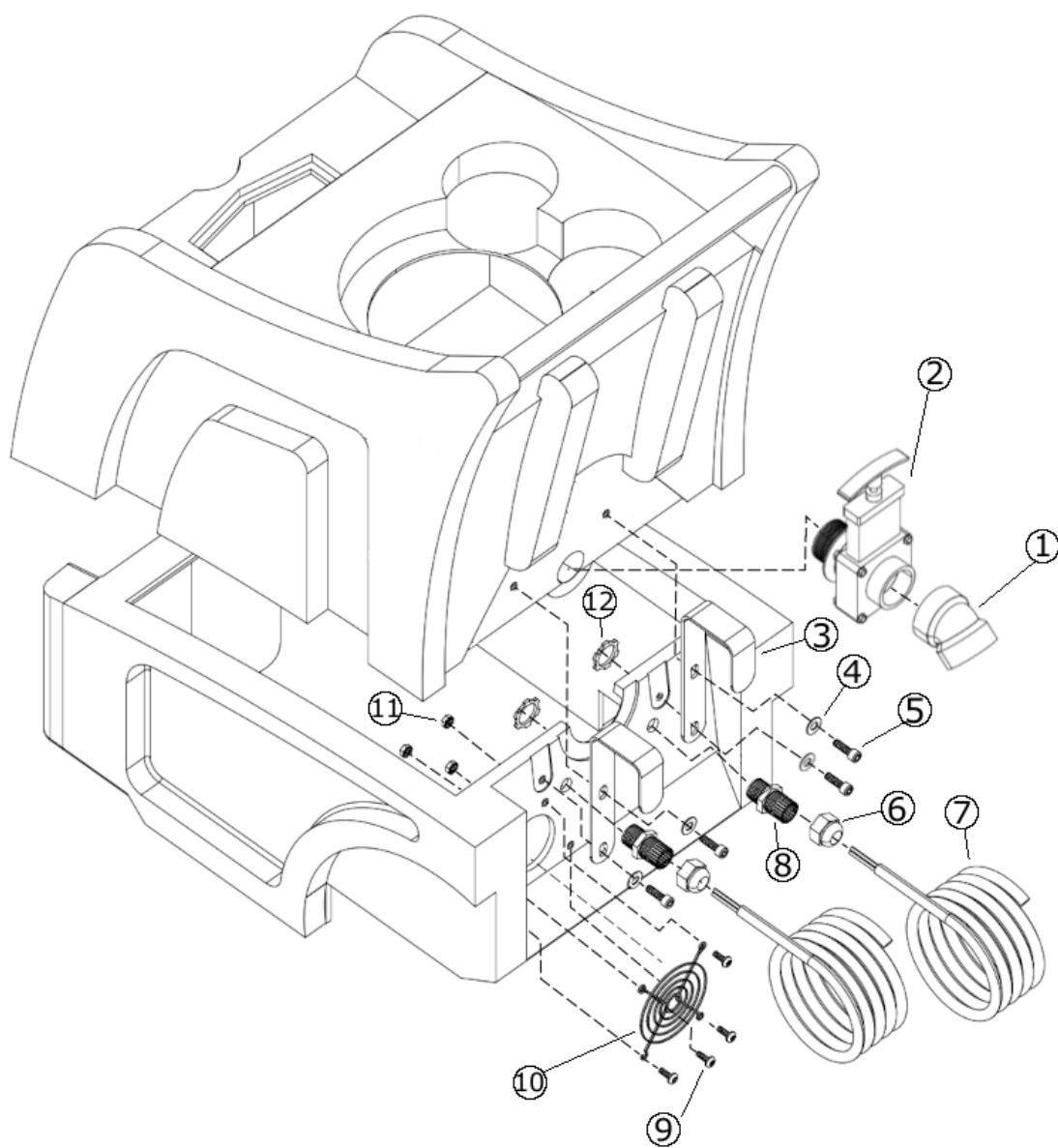

Ninja 500 2 – 3 Stage

REF	PART NO.	DISCRIPTION	NOTES
1	588-020	ABS ELBOW 45, 1 1/2" SLP X SLP	
2	545-100	.DUMP VALVE, 1 1/2" (FLANGE-MPT)	
3	465-075	POWER CORD , BRACKET	
4	415-125	FW, 1/4 SS	
5	410-410	CS, 1/4-20 X 3/4 SOC S/S	
6	335-015	STRAIN RELIEF, 14 GAUGE	
7	315-015	CORD, 25' BLACK 14/3 SJTW-A	
8	335-015	STRAIN RELIEF, 14 GAUGE	
9	410-205	MS, 10-32 X 1/2 PANPHIL SS	
10	560-325	GUARD, FINGER - 4" MUFFIN FAN	
11	400-043	NUT, 10-32 KEPS LOCKNUT	
12	400-165	LOCKNUT, 1/2" STEEL / STRAIN RELIEF	

Ninja 500 2 – 3 Stage

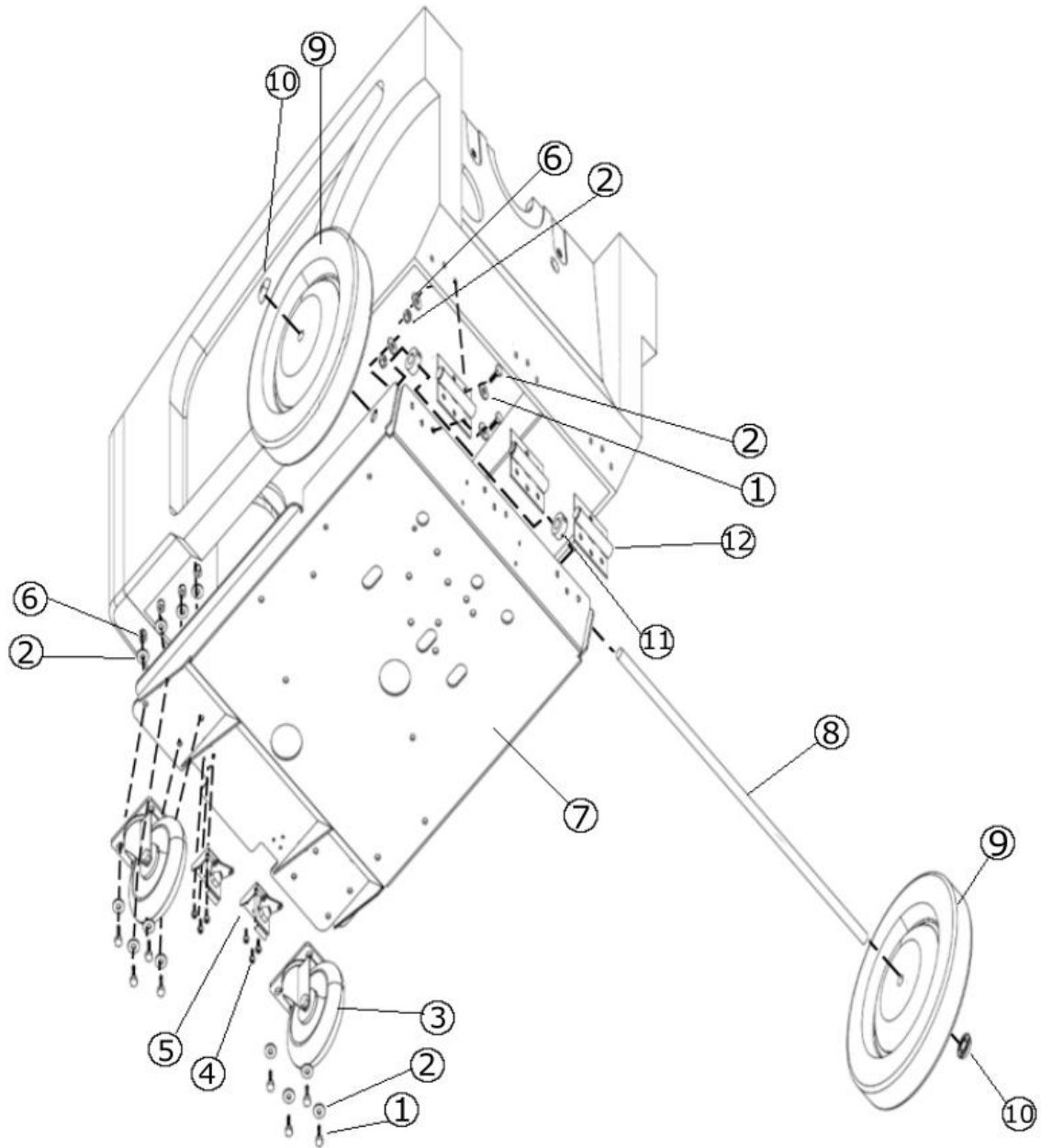

Ninja 500 2 – 3 Stage

REF	PART NO.	DISCRIPTION	NOTES
1	415-120	FW, 1/4 ZINC	
2	405-620	BOLT, 1/4X3/4 SS(HEX HD)	
3	455-006	CASTER, 5" SWIVEL	
4	410-205	MS, 10-32 X 1/2 PANPHIL SS	
5	445-012	LATCH	
5A	445-013	KEEPER	Not Shown
6	400-135	LOCKNUT, 1/4 X 20 NYLON ZINC	
7	845-095	PLATE, BASE, DEFENDER	
8	470-065	AXLE, DEFENDER	
9	455-060	WHEEL, 10"	
10	455-052	WHEEL CAP DOME - 1/2" METAL	
11	385-050	COLLAR, 1/2" SHAFT - HM	
12	440-020	HINGE, DEFENDER, PAIR	

Ninja 500 2 – 3 Stage

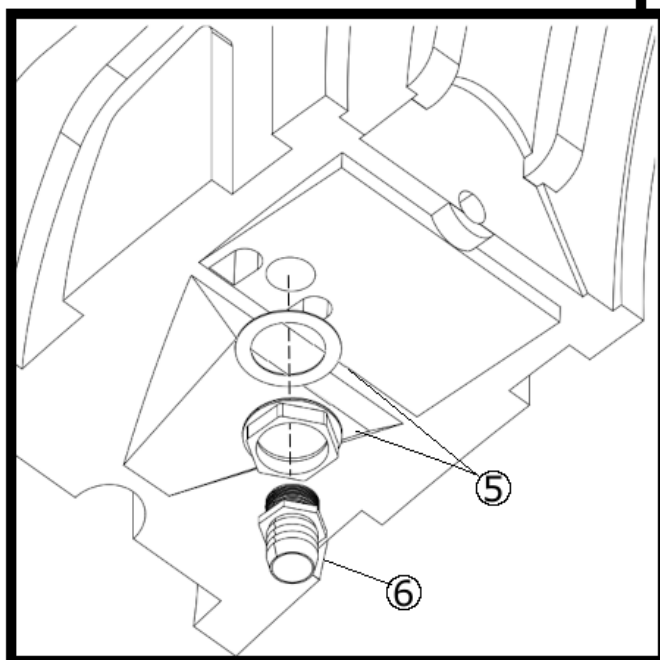
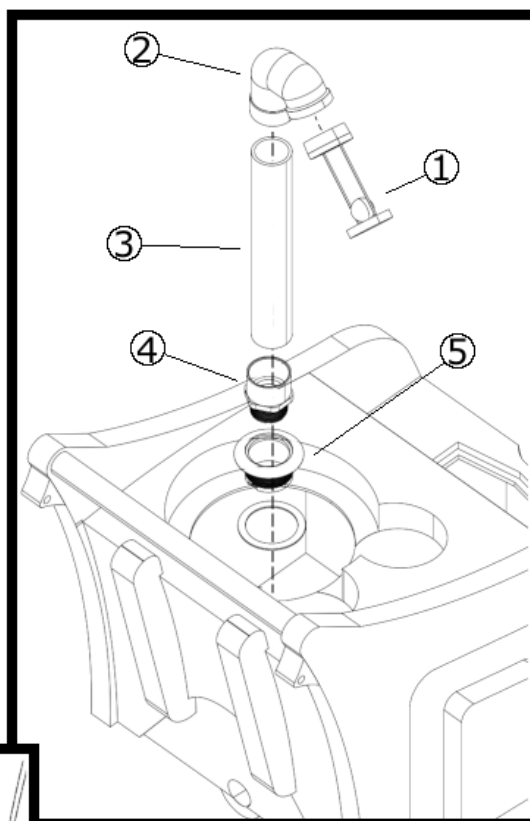

Ninja 500 2 – 3 Stage

REF	PART NO.	DISCRIPTION	NOTES
1	597-010	FLOAT SCREEN CAGE - 1 1/2	
2	597-061	ADPT (RM) 30 DEGREE, FLOAT SCREEN 1 1/2"	
3	595-005	ABS PIPE, 1 1/2"	
4	590-415	PVC ADPT 1 1/2", S x MPT	
5	590-205	PVC WALL FITTING, 1 1/2"	
6	590-405	PVC HOSE BARB 1 1/2" x MPT	

Ninja 500 2 – 3 Stage

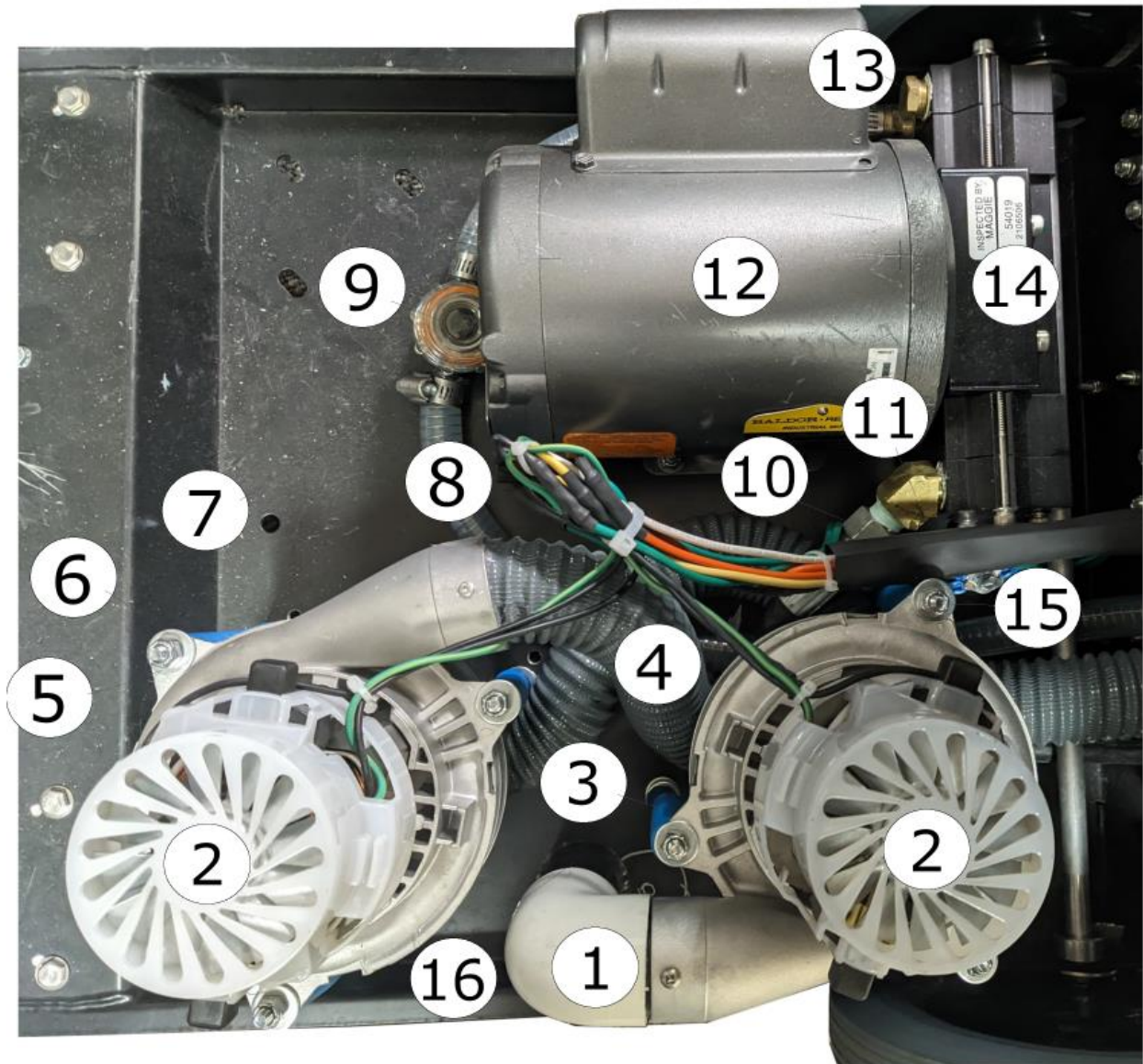

Ninja 500 2 – 3 Stage

REF	PART NO.	DISCRIPTION	NOTES
1	590-010	PVC ELBOW 1 1/4" 90, S x S	
2	355-405	VAC CAP W/STRAIGHT ADPT	
2A	355-420	VACUUM MOTOR 3 STAGE (AMETEK) w/adapter	
3	572-041	L.P. HOSE 3/8 BLUE	
4	570-010	VAC HOSE, 1 1/2" WIRE REINFORCED	
5	400-135	LOCKNUT, 1/4 X 20 NYLON ZINC	
6	415-120	FW, 1/4 ZINC	
7	425-010	CLAMP, #20 HOSE 13/16 X 1 3/4	
8	572-155	POLYSPRING HOSE, 1/2"	
9	560-116	STRAINER, INLINE BARBED 1/2"	
10	581-065	CRIMP FTNG, 3/8" PULSE HOSE 1/4 MPT SVL	
10A	572-125	PULSE HOSE, 3/8"	
11	555-182	ELBOW 45, 1/4" FEM. EXTRUDED	
12	512-551	MOTOR, MODEL M110	
12A	512-542	PUMP, 500 (207) & M110 MOTOR	
13	555-454	PLUG, 3/8 MPT HEX HEAD	
14	512-585	PUMP 500 - 207V	
15	405-065	BOLT, 1/4 X 6 RH STOVE ZINC(ALL THREAD)	
16	595-004	ABS PIPE, 1 1/4"	

PUMP 500 PARTS LIST

